



Ford C6/E4OD/4R100 Forward Clutch PowerPack® 66-On

ALTO PART # 026755A

Alto # 026755A POWERPACK® CONTENTS:

- (6) 026710 Friction Plates
- (6) 026701A Steel Plates
- (1) 026760-630 Top Pressure Plate
- (1) 026760A673 Bottom Pressure Plate

INSTALLATION INSTRUCTIONS

Stack up is the same method as OE. Start with the bottom apply plate dished side down. Install the cushion spring then alternately install the friction and steel plates starting with a steel and ending with a friction plate. Install the top pressure plate and the selective snap ring.

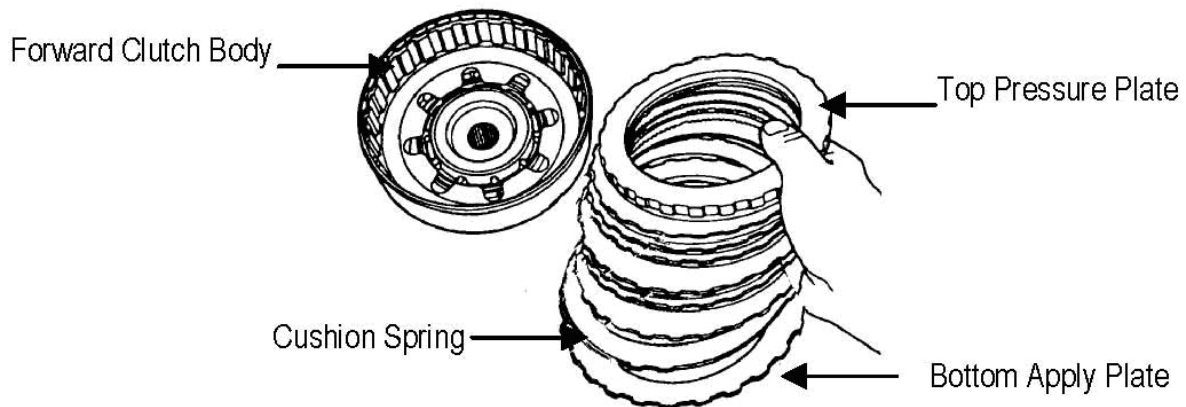

Note: Always pre-soak friction elements for at least 15-20 minutes in manufacturer recommended ATF.

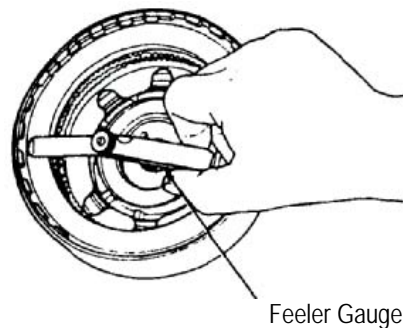

Apply air to assembled clutch pack several times to seat the friction and steel elements. Using a feeler gauge measure between the bottom of the selective snap ring and the top of the pressure plate. Clearance should be .040" to .075" (1.02 to 1.91mm). Adjust clutch pack clearance by selecting the correct selective snap ring.

The following Selective Snap Rings are available from Alto: 026251-050; 026251-058; 026251-062; 026251-076; 026251-090; 026251-094; 026251-112; 026251-130. Please contact your sales representative for more information.