

New Process 230 & 240 Series

Split Ring Retainer

Part No.
100420-01K

- Snap Ring
- Retainer Ring
- Split Retainer

NOTE: 230 Series with 1.180" diameter shaft.

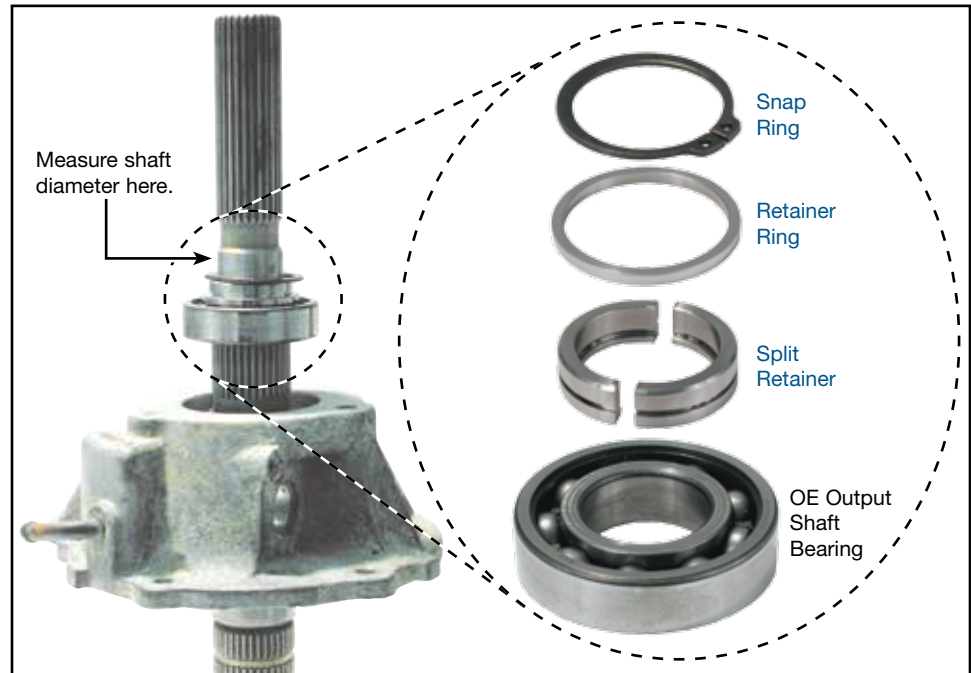

1. Disassembly

Remove OE retaining ring.

2. Installation & Assembly

- Place the two halves of the split ring retainer around the output shaft.
NOTE: The end of the retainer with the chamfer on the O.D. should face away from the bearing.
- Place the solid retaining ring over the split retainer. Slide it over the split retainer until it is in contact with the bearing.
- Install the snap ring into the groove on the split ring retainer. This will keep the assembly together (**See illustration**).

