

O-Ringed End Plug Kit

Part No.
104740-23K

- End Plugs (6)
- O-Rings (9)

3 Extra

GM 6L45, 6L50, 6L80, 6L90

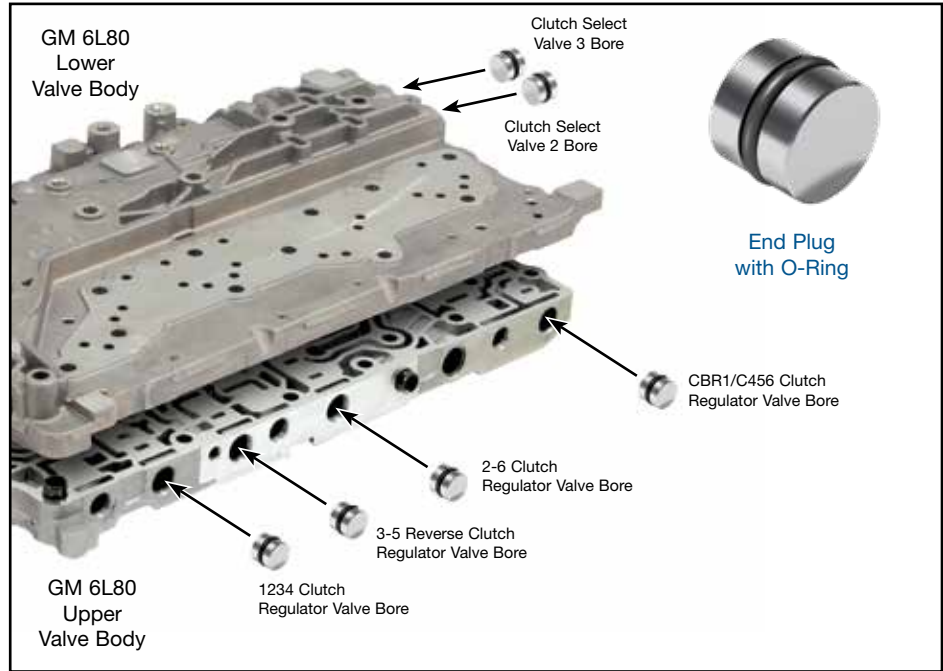

1. Dissassembly

- Remove OE plug retainers and keep for reuse.
- Remove and discard OE end plugs.

2. Installation & Assembly

- Install Sonnax O-ring in shallow groove on Sonnax end plug. Then lubricate with Sonnax Slippery Stick **O-LUBE** and roll on bench to size the O-ring in the groove.
- Carefully insert Sonnax O-ringed end plug into the bore just far enough to reinstall the OE retainer.

NOTE: A small, flat-bladed screwdriver inserted through the retainer port cavity may be used to help compress the O-ring into the bore.

3. Final Testing

Vacuum tests at the ports indicated hold the recommended minimum of 18 in.-Hg.

