

Oversized TCC Control Valve Kit

Part No.
144510-07K

- Valve
- Spring



Tool Kit

Part No.
F-144510-TL7C

- Reamer
- Reamer Jig
- Guide Pin



Carbide

NOTE: Sonnax "F-Tool" kits designed to service a specific bore require the VB-FIX, a self-aligning valve body reaming fixture. More information and instructions can be found online at www.sonnax.com.

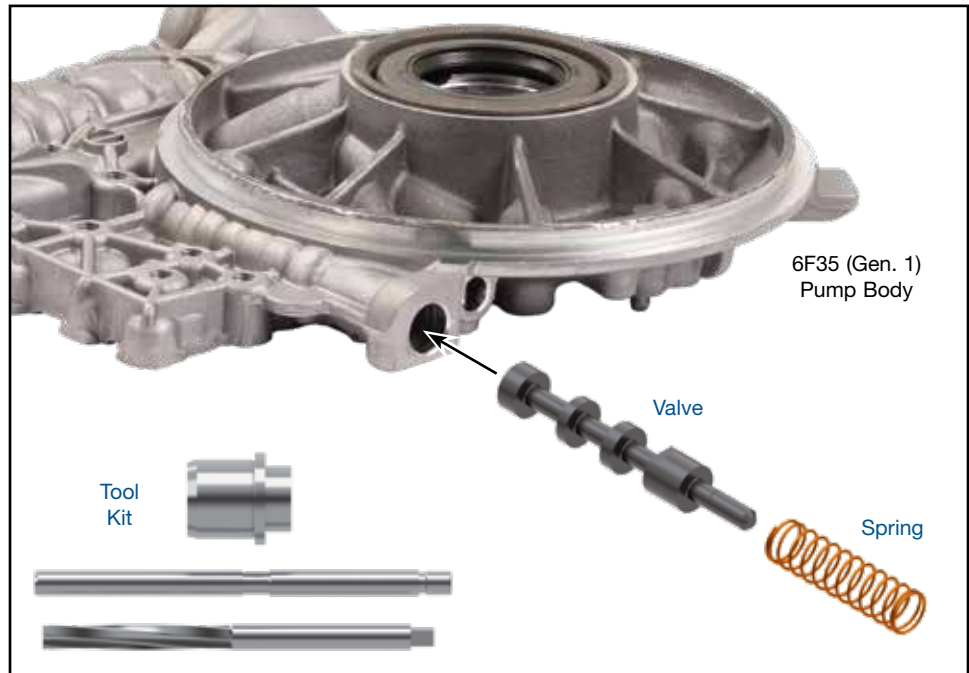

1. Disassembly

- Remove OE retainer clip and save for reuse.
- Remove OE spring and TCC control valve and discard.

2. Bore Reaming



NOTE: Pump is low-profile and must be secured 1/2" above the VB-FIX base plate in order to establish alignment with the bore. Transmission pressure plates stacked under the pump work well for this purpose. If pressure plates are used, the pump securing clamp **MUST** be placed directly over the plate stack. Clamping on an unsupported area of the pump or over the bore to be reamed will cause distortion and result in irreparable damage to pump.

Ream TCC control bore (for reaming instructions/reamer care, please visit www.sonnax.com). Sonnax reaming tool kit **F-144510-TL7C** and **VB-FIX** are required for this operation.

3. Installation & Assembly

- Be certain all debris has been removed from valve bore and pump body.
- Install Sonnax oversized TCC control valve and spring.
- Reinstall OE retainer clip.

4. Final Testing

Vacuum testing at the port(s) indicated holds the recommended minimum 17 in-Hg.

