

Signal Accumulator Piston Kit

Part No.

154740-06K

- Sleeves (4)
- Pistons (4)
- Springs (4)
- O-Rings (6) 2 Extra
- End Plugs (4)

NOTE: Kit includes 4 piston sets which fit any of 7 locations.

Patent Pending

GM 8L45, 8L90

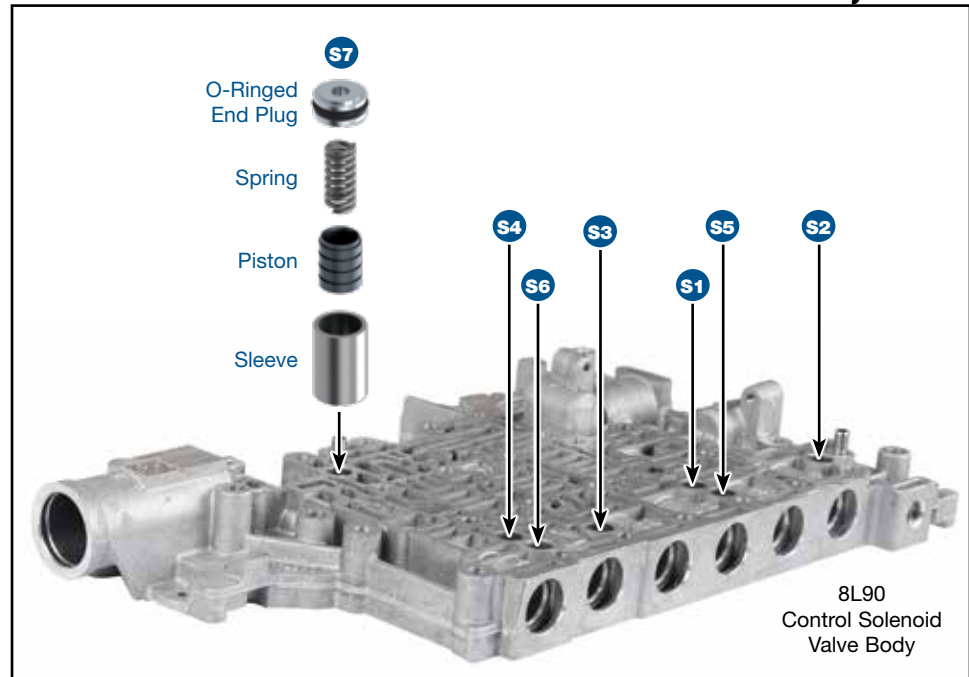

1. Disassembly

Remove and discard OE accumulator pistons and springs.

2. Installation & Assembly

- a. Install Sonnax sleeve into OE casting bore.
- b. Install Sonnax piston into sleeve with open end facing upward.
- c. Install Sonnax spring into piston spring pocket.
- d. Install O-ring into groove in Sonnax plug. Lubricate with Sonnax Slippery Stick **O-LUBE** and roll on bench to size.
- e. Install O-ringed end plug into bore with recessed end upward. The small boss on the O-ring should slide into the installed sleeve inner diameter.



Figure 1

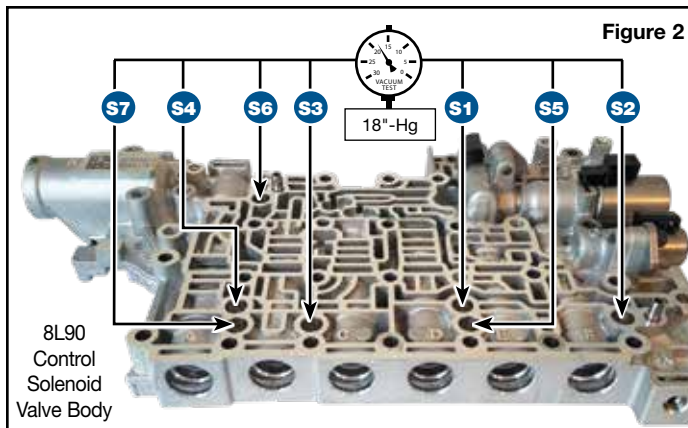

Figure 2

3. Final Testing

NOTE: Initial vacuum testing of the OE line-up should utilize the test plate included with the VACTEST-01K. For most accurate testing of the installed Sonnax kit, vacuum testing should be conducted by installing a small test tip into the plug hole (Figure 1).

Vacuum testing at the port(s) indicated holds the recommended minimum 18 in-Hg (Figure 2).