

*Parts are labeled here in order of installation. See other side of sheet for details on Sure Cure kit contents.
See Sure Cure instruction booklet for detailed installation steps.*

VALVE BODY INSTALL DIAGRAM

48RE Valve Body I.D. Locations

(These features are not present on the 46/47RE units.)

48RE valve bodies have this passage in the transfer plate.

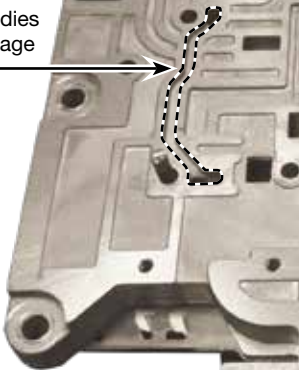

Transfer Plate

48RE valve bodies have these 3 holes in the upper separator plate.

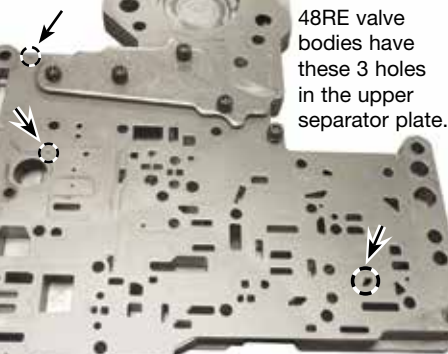

Upper Separator Plate

Lower Separator Plate

48RE valve bodies have these holes in the lower separator plate.

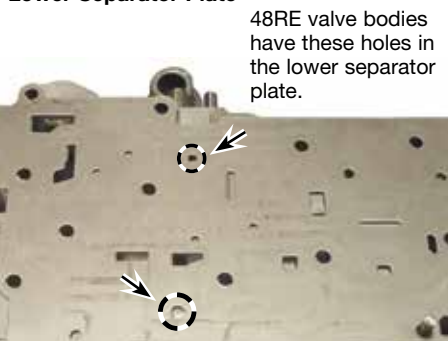

CAUTION: This sheet is NOT intended to be a quick install guide. Not ALL steps/parts are shown here. See other side for details and use in conjunction with instruction booklet.

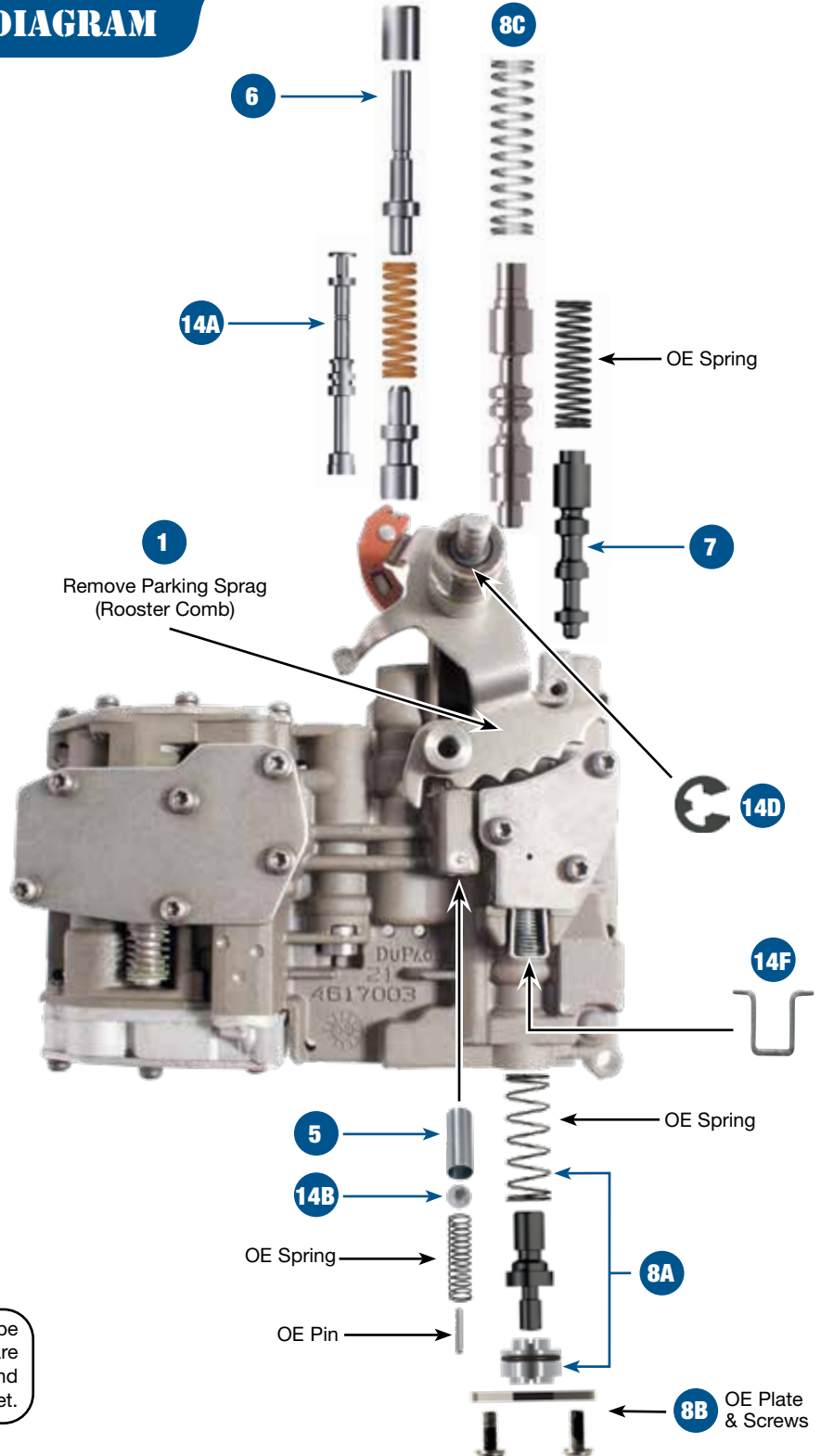

Sure Cure Contents & Installation Steps See instruction booklet for detailed instructions.

Step 1 Disassemble Valve Body & Manual Lever

Step 2 Ream Lube Regulated PR Valve & Line/TV Pressure Plug Bore

NOTE: Requires Sonnax tool kit F-22771A-TL7 and VB-FIX alignment fixture, not included in this kit.

Step 3 Ream Throttle Valve Bore

NOTE: Requires Sonnax tool kit F-22771-TL and VB-FIX alignment fixture, not included in this kit.

Step 4 Ream Switch Valve Bore

NOTE: Requires Sonnax tool kit 22771A-TL13.

Step 5 Ream Detent Bore & Install Detent Sleeve & Pin

NOTE: Requires Sonnax tool kit 22771-TL12 not included in this kit.

Packaging Pocket 1

- Sleeve
- Detent Ball (*ball installed in Step 14*)

Step 6 Install Oversized Throttle Valve Kit

Packaging Pockets 2 & 3

- Valve
- Plunger
- Sleeve
- Orange Spring

NOTE: Shims and spring from 22771-04K kit are not included in this Sure Cure.

Step 7 Install Oversized Four-Spool Switch Valve

Packaging Pocket 4

Four-Spool Switch Valve

Step 8 Install Oversized Lube Regulated Pressure Regulator Valve & Line/TV Pressure Plug Kit

Packaging Pocket 5 & 6

- Lube Regulated PR Valve
- White Spring
- Line/TV Pressure Plug Assembly

Step 9 Separator Plate Modification

NOTE: The parts listed here may be protected by patent numbers 6,689,007 and 6,712,726.

Step 10 Install 3-4 Accumulator Spring & Seals

Packaging Pocket 10

- 3-4 Accumulator Spring
- 4th Accumulator Seal
- 4th Accumulator D-Ring

Step 11 Vacuum Test Verification

Step 12 Assemble Valve Body Sections

Packaging Pocket 8

Checkball, .188" dia.

Step 13 Install Adjusting Screw Bracket & Adjust PR Spring

Step 14 Install Manual Valve with OE Manual Lever (Rooster Comb), Boost Valve Spring Retainer & Adjust TV Pressure Screw

Packaging Pocket 12

- Manual Valve
- Shift Linkage E-Clip
- Boost Valve Spring Retainer
- Detent Ball (*included in Step 5 kit*)

Step 15 Install Intermediate Plug & Pilot Kit

Packaging Pocket 7

- Shaft Pilot
- Cup Plug

Step 16 Install Output Pilot Bushing

Packaging Pocket 9

Bushing

Step 17 Install 6-Tab Thrust Washers

Packaging Pocket 11

Thrust Washers (2)

Step 18 Install Turbine Shaft Seals

Packaging Pocket 11

Seals (2)

Technical Specifications

Pump-to-Stator Bolts 15 ft-lb	Valve-Body-to-Case Bolts 106 in-lb
Pump-to-Case Bolts 15 ft-lb	OE Endplay .034-.084"
Valve Body Assembly Bolts 35 in-lb	

NOTE: This 48RE Sure Cure kit fits 2002-2004 TV lever-style transmissions as well as the 2005 and newer 48RE with the transmission throttle actuator (TTVA) motor.

PART INSTALLATION: To implement best practices and avoid chip contamination, wait until all valve body reaming operations are finished before installing Sonnax products. Detailed installation instructions steps are explained later in this booklet.

F-TOOL REAMING: Visit Sonnax web site www.sonnax.com for general F-Tool reaming fixture instructions, as well as best practices for bore preparation, cautions and suggestions on bore reaming.

Step 1 Disassemble Valve Body & Manual Lever

- a. Remove shouldered bolt retaining the solenoid wiring harness case connector to the valve body.
- b. Secure manual lever detent ball by using a dull wood workers gouge tool to compress the detent ball while removing the manual lever (**Figure 1**).



CAUTION: The detent ball and spring will launch out of the detent bore by spring tension if not retained during manual lever removal. Never reuse the OE detent ball with the Sonnax sleeve. The Sonnax ball is specially toleranced to work with the Sonnax sleeve, preventing binding of the ball in the bore.

- c. Remove OE E-clip, washer and manual lever from valve body. Slide out throttle lever. Discard detent ball. Save detent spring for reassembly.
- d. Disconnect governor pressure sensor and governor pressure solenoid connectors.
- e. Remove governor body screws and then governor body.
- f. Take out three screws holding overdrive/lockup solenoid from lower casting. Then, remove solenoids with wiring harness from valve body.



CAUTION: The pressure adjusting bracket is under spring tension by the pressure regulator and switch valve springs.

- g. Remove the center screw from the adjusting screw bracket. Temporarily remove one of the long screws holding the three valve body castings together and install it in place of the center screw (**Figure 2**). This will help to hold the bracket in place when removing the upper and lower screws. Remove the upper and lower bracket screws while holding the adjusting screw bracket. Remove the center screw. Save the OE switch valve spring, line pressure screw and adjusting bracket for reassembly. Discard the OE pressure regulator spring.
- h. Remove two screws holding the throttle pressure plug retaining plate. Remove the retaining plate, sleeve, plug, and spring from valve body. Discard the OE plug and sleeve. Save OE spring for reassembly.
- i. Bend tabs securing boost valve tube to valve body. Then, remove OE boost valve tube.
- j. Remove the bolts from the lower housing which clamp the three valve body castings together.
- k. Remove and discard OE switch valve and pressure regulator valve. Remove throttle valve assembly, discarding all parts except the TV and switch valve springs which will be reused at assembly.
- l. Remove all the remaining valves and springs from the upper casting. Reinstall valves and springs after all reaming operations are completed.

- m. Disassemble, clean and reassemble the lower casting.

NOTE: The only casting requiring reaming is the upper casting.

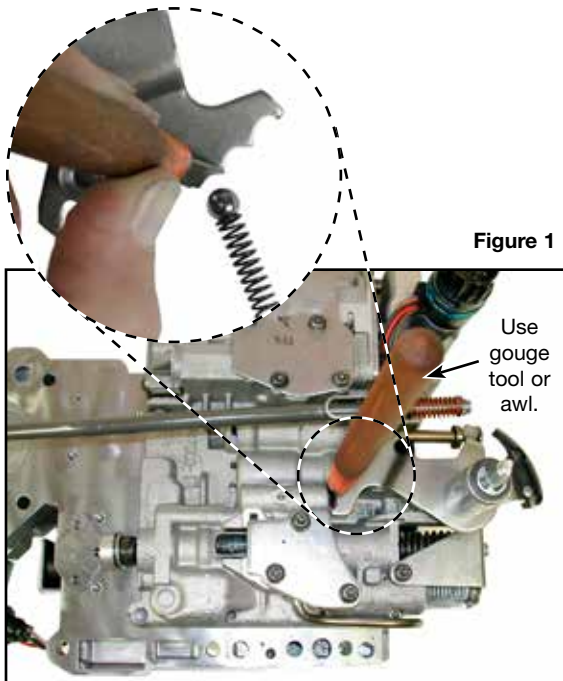

Figure 1

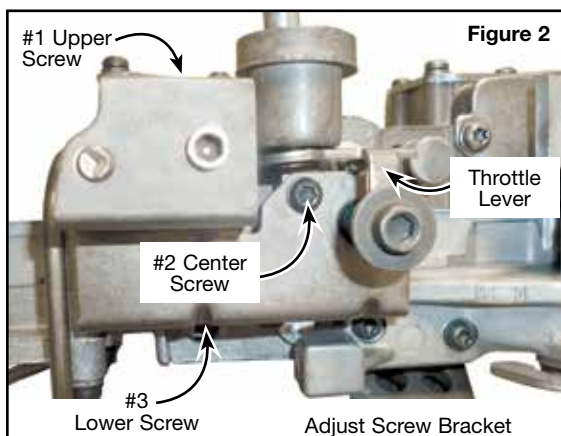

Figure 2

Step 2 Ream Lube Regulated PR Valve & Throttle Pressure Plug Bore

1. Valve Body Inspection

If a line-to-lube hole has been drilled in the PR valve circuit, it should be plugged to reduce converter drainback.

2. Ream Bores

NOTE: These two bores require the use of tool kit **F-22771A-TL7** and the alignment fixture **VB-FIX** (not included in this kit). See page 8 for details on standard Sonnax bore preparation and reaming procedures.

- Align **VB-FIX** to ream the pressure regulator bore using jig **F-22771A-RJ** and guide pin **F-22771A-GP**.
- Ream the pressure regulator bore using reamer **F-22771A-RM**.
- Align **VB-FIX** to ream the throttle pressure plug bore using jig **F-22771A-RJ2** and guide pin **F-22771A-GP2**.
- Ream throttle pressure plug bore using reamer **F-22771A-RM2**.

NOTE: Do not install valves at this time. Wait until all reaming operations are finished.

Step 3 Ream Throttle Valve Bore

NOTE: This bore requires the use of tool kit **F-22771-TL** and the alignment fixture **VB-FIX** (not included in this kit). See page 8 for details on standard Sonnax bore preparation and reaming procedures.

- Align **VB-FIX** to ream the throttle valve bore using jig and guide pin provided in the tool kit.
- Ream the bore using the reamer provided in kit.

NOTE: Do not install valves at this time. Wait until all reaming operations are finished.

Step 4 Ream Switch Valve Bore

NOTE: This bore requires the use of tool kit **22771A-TL13** (not included in this kit). See page 8 for details on standard Sonnax bore preparation. These piloted reamers do not require a reamer guide.

1. Ream bore with stepped reamer 22771A-RM13

- Insert reamer into bore until chamfered cutting tip contacts inner bore opening. Using a speed handle, ream bore clockwise at one to two turns per second. This reaming operation should take approximately 1 minute.
- With low air pressure and reamer still in bore, blow chips out of bore.
- Turning clockwise, remove the reamer from the bore. Clean the remaining chips from the bore.

2. Ream bore with reamer 22771A-RM14

- Insert Sonnax reamer **22771A-RM14** into bore until chamfered cutting tip contacts inner bore opening.
- Using same procedure as above, ream the same bore. This second reaming operation should take approximately 1 minute as well.

NOTE: Do not install valves at this time. Wait until all reaming operations are finished.

Step 5 Ream Detent Bore & Install Detent Sleeve & Pin

NOTE: This bore requires the use of tool kit **22771-TL12** (not included in this kit). See page 8 for details on standard Sonnax bore preparation procedures.

1. Disassembly

Remove and save the OE retaining pin.

NOTE: It is recommended to use a Dremel® #194 drill bit or .120" diameter drill bit to remove some of the swaged aluminum over the top of the retaining pin. Damage could occur to the enclosed .096" drill bit if used for material removal.

2. Ream Bore

- Securely clamp the valve body to the bench.
- Soak the bore and reamer with cutting fluid.
- Insert the pilot on the self-guiding reamer into the retaining pin end of the detent bore until the cutting chamfer contacts the face of the bore (**Figure 3**).
- Use a speed handle to turn the reamer in the bore. The reaming action should be clockwise in a smooth and continuous motion, 60-120 RPM.
- Continue reaming until the reamer cutting chamfer passes fully through the opposite end of the detent bore.
- Using low air pressure, blow the chips free prior to removing the reamer.
- To remove the reamer, turn clockwise while slowly pulling outward on the reamer.

3. Install Detent Sleeve & Pin (Figure 4)

NOTE: The Sonnax sleeve is designed as a slip fit, and is secured by drilling through the sleeve with the tool kit drill bit and reinstalling the OE retaining pin. However, it is highly recommended that Loctite® (or equivalent) be used with the sleeve.

- Secure the Sonnax sleeve in the detent bore using Loctite® retaining compound per the manufacturer's directions.
- The sleeve should be pushed in until the face is flush with the face of the ball end of the detent bore.

NOTE: Before drilling, it helps to use the retaining pin as a center punch and make a slight indentation in the sleeve to hold the drill bit on-center and prevent the drill bit from walking off and making the pinhole in the casting larger.

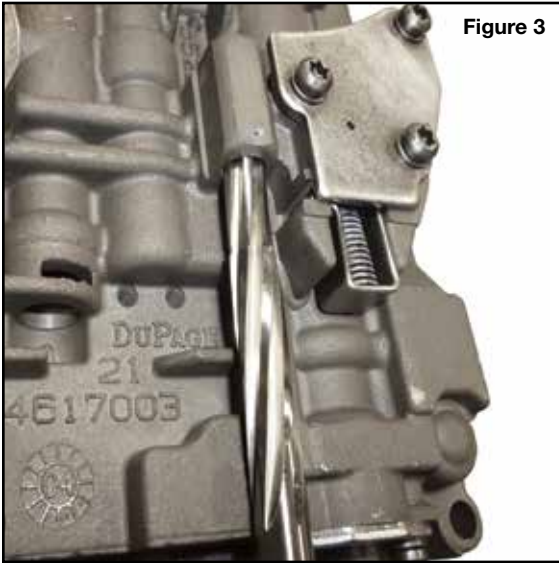

Figure 3

c. After the Loctite® has cured, use the existing retaining pinhole in the casting to guide the drill bit through both sides of the sleeve.



CAUTION: Do not drill any deeper than the depth of the pin.

d. Reinstall the OE retaining pin and use a flat blade screwdriver, center punch or other tool to swage the aluminum casting over the top of the pin. Confirm retaining pin is secured in place.

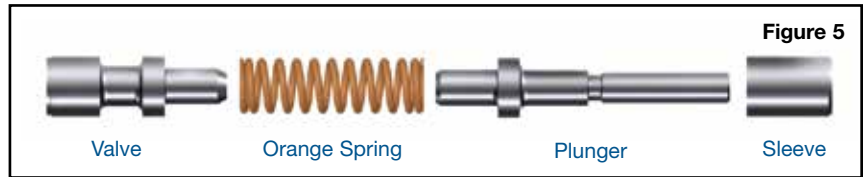

Figure 5

Step 6 Install Throttle Valve Kit (Figure 5)

- Install Sonnax oversized throttle valve.
- Install Sonnax throttle valve spring.
- Install Sonnax throttle plunger and sleeve, with cupped side of sleeve facing inboard.

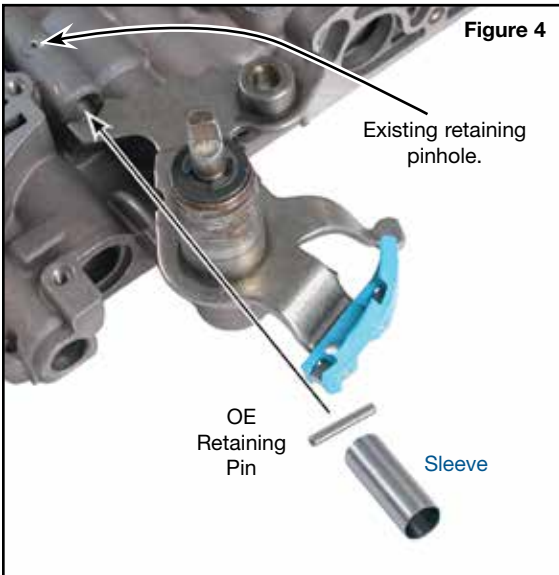

Figure 4

Step 7 Install Oversized Four-Spool Switch Valve (Figure 6)

Install Sonnax oversized switch valve. The OE switch valve spring will be installed while installing the pressure adjusting bracket in Step 13 (Figure 18).

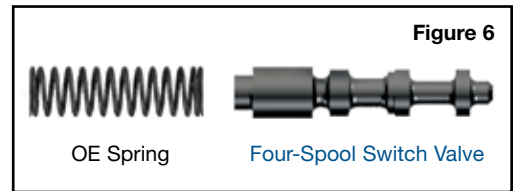

Figure 6

Step 8 Install Lube Regulated PR Valve & Line/TV Pressure Plug Kit

a. At the opposite end of the pressure regulator bore, reinstall the OE throttle spring, followed by the Sonnax oversized line/TV pressure plug assembly (Figure 7).

b. Install the OE end plate with the two screws.

NOTE: Check to be sure the end cap (plate) sits flush against the valve body and seals the bore. If the plate is not flush, remove material from the outboard castled side of the O-ringed sleeve. Remove the minimum material necessary to allow the plate to seal the bore. Do not remove more than .015" [0.38 mm] total from the sleeve.



CAUTION: Pressure leaking at the plate will result in increased line pressure.

c. Install Sonnax pressure regulator valve. The Sonnax white-striped spring will be installed later in Step 13.

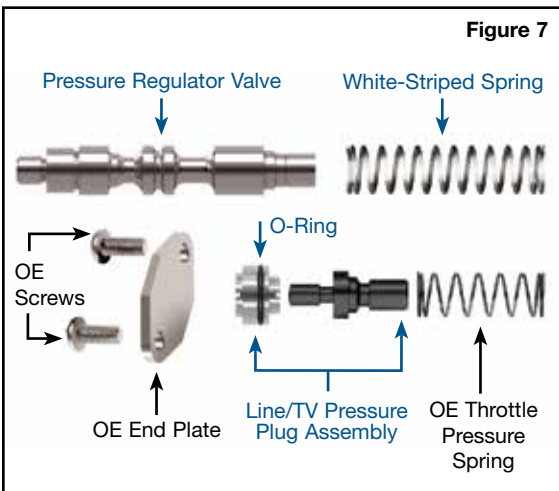

Figure 7

OE Throttle Pressure Spring Specs	
Free Length	1.460"
Wire Diameter	.035"
Number of Coils	6

NOTE: Chart for reference only.

Step 9 Separator Plate Modification

Enlarge TRE orifice in OE separator plate from original size .045" to .062" (Figure 8).



CAUTION: Drilling larger than .062" will create a bump on TCC apply.

- a. Drill with 1/16" (.062") drill bit.
- b. Remove burrs with a large drill bit.

Step 10 Install 3-4 Accumulator Spring & Seals (Figure 9)

1. Disassembly

- a. Remove cover plate and screws.
- b. Remove and discard OE piston spring.
- c. Remove OE piston and save for reuse.
- d. Remove and discard the OE seals from the OE piston.

2. Installation (Figure 10)

- a. Use red-colored Scotch-Brite™ to remove glaze from bore. Clean bore until spotless.
- b. Install Sonnax seal by the open end of the piston.
- c. Install Sonnax D-ring by the closed end of the piston.
- d. Install OE piston, then Sonnax spring.



CAUTION! The 4th accumulator D-ring can be easily cut on hole edge in accumulator bore during installation.

Step 11 Vacuum Test Verification

NOTE: To verify reaming operations use Sonnax vacuum test stand kit **VACTEST-01K** (not included with this kit).

A vacuum test at the ports indicated should hold the recommended in-Hg of vacuum or more (Figure 11).

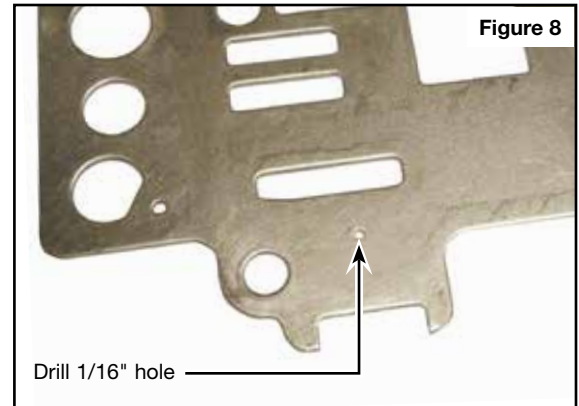

Figure 8

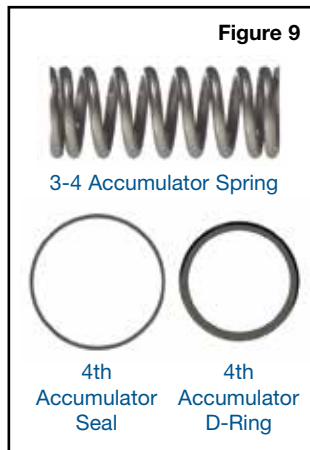

Figure 9

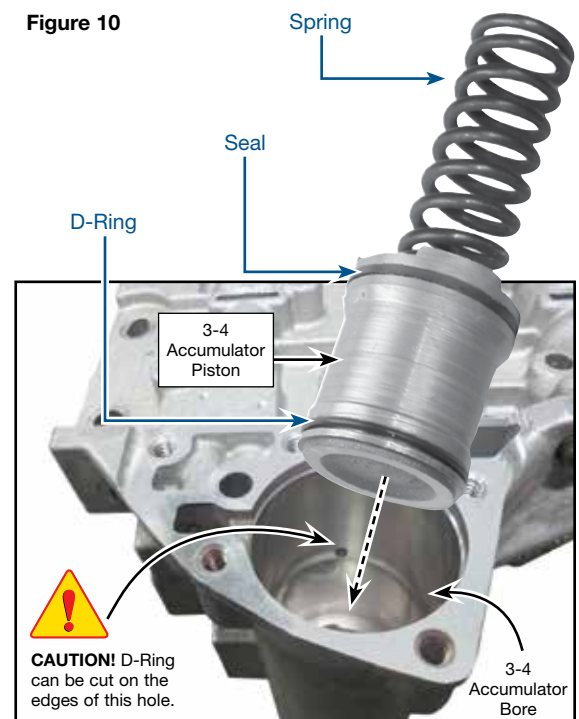

Figure 10

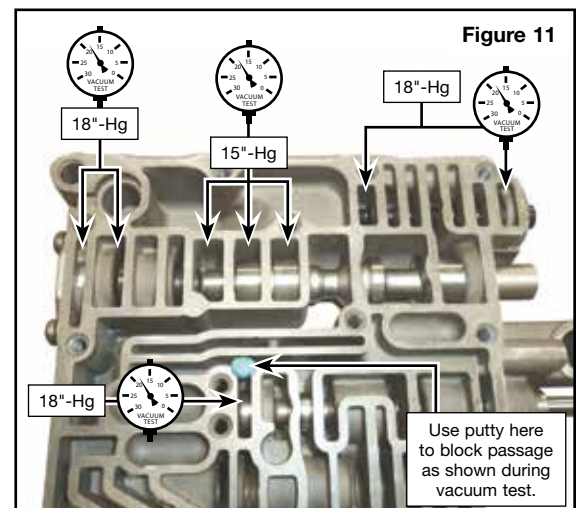

Figure 11

Step 12 Assemble Valve Body Sections

- a. Install either five or six OE 1/4" checkballs and one OE 11/32" checkball into the upper housing (Figure 12).
- b. Install two OE 1/4" checkballs into the upper side of transfer plate (Figure 13).
- c. Install separator plate and filter onto transfer plate and tighten the five OE plate bolts to 35 in-lb (Figure 14).

NOTE: It is helpful for plate alignment to use drill bits in the two machined holes as shown (Figure 14). Once plates are aligned, remove drill bits.

- d. Set transfer plate onto upper housing. Install the Sonnax 3/16" checkball (Figure 15).
- e. Set separator plate onto transfer plate (Figure 16).
- f. Install lower housing onto transfer plate. Install and torque the valve body bolts (Figure 17).
- g. Install boost tube and bend tabs to retain it.

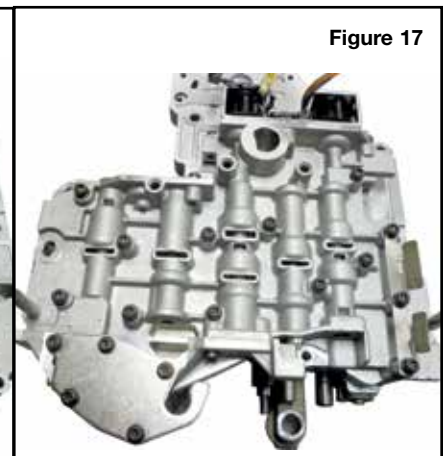
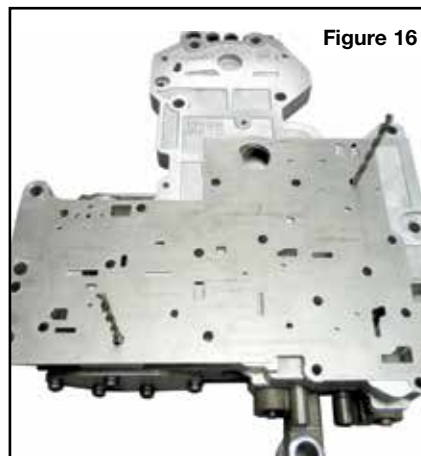
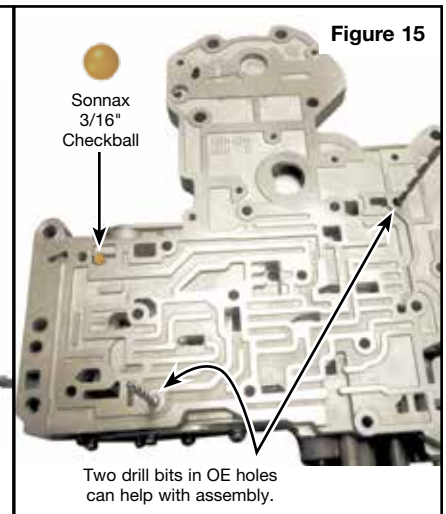
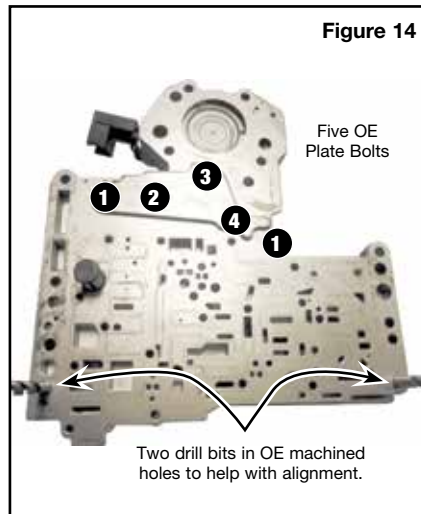
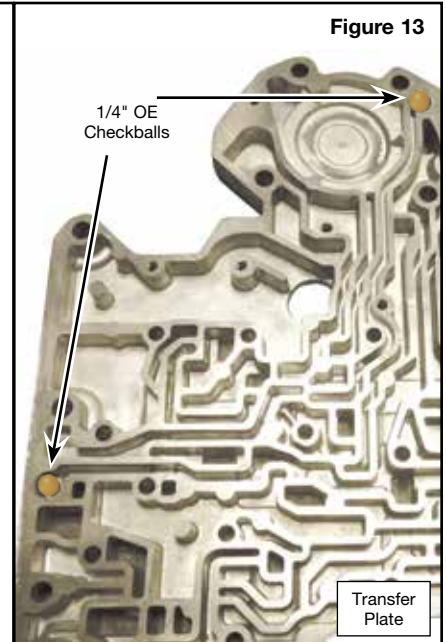
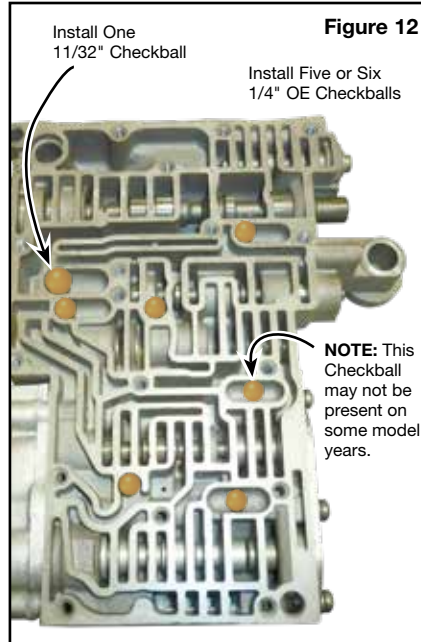

Step 13 Install Adjusting Screw Bracket & Adjust Pressure Regulator Spring

- Place line pressure adjusting screw in the bracket.
- Position OE switch valve spring over boss on bracket.
- Install Sonnax white-striped spring on the pressure regulator valve.
- Install the adjusting screw bracket (**Figure 18**) on valve body, making sure Sonnax pressure regulator spring and OE switch valve spring are aligned correctly.
- Temporarily install one of the long valve body bolts in the center bolt hole as this simplifies installation.
- Install the short upper screw first, followed by lower screw but do not tighten.
- Remove the long screw, install a short screw in the center.
- Starting with the center screw first, tighten the three bolts retaining the adjusting screw bracket to the valve body.
- Adjust pressure regulator screw so the inside edge of plate is 1.310" from valve body casting (**Figure 19**).
- Verify pressure adjustment by connecting a pressure gauge to the transmission. Pressure should be 55–60 PSI in drive.

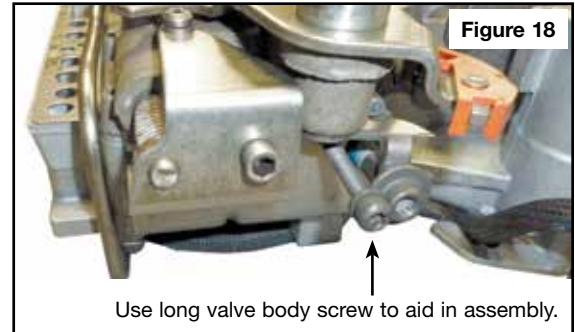

Step 14 Install Manual Valve with OE Manual Lever (Rooster Comb), Boost Valve Spring Retainer & Adjust TV Pressure Screw

- Install Sonnax manual valve (**Figure 20**).
- Install OE detent spring and Sonnax detent ball (**Figure 20**). Hold in place with wood workers gouge tool (**Figure 1**, page 1).
- Place the throttle lever (**Figure 2**) in the upper housing. Install manual lever over throttle lever while aligning the manual lever with the manual valve (**Figure 21**).
- Install OE throttle lever shaft seal with lip up to keep moisture out. Then install OE washer and Sonnax E-clip (**Figure 20**).
- Adjust throttle valve by using special Chrysler tool #C-3763 or equivalent such as the one shown (**Figure 22**). The length of the "hammer head" part of the tool is .627". Compress the TV plunger with tool until the plunger is bottomed in the valve body. Adjust the TV adjustment screw with an allen wrench until the screw just contacts the TV lever while the TV lever is in contact with the TV plunger.

NOTE: The spring is under considerable tension when the TV plunger is fully depressed. Be sure the spring is compressed and TV plunger is contacting the TV valve while making this adjustment. TV valve will be fully bottomed in the bore.

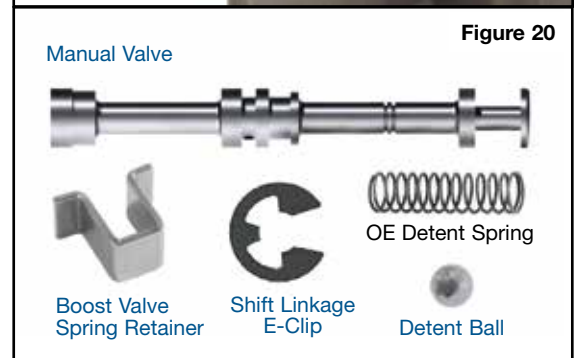



IMPORTANT! This adjustment is critical on 2005-later models which use a Transmission Throttle Valve Actuator (TTVA). The ECM needs to see the TTVA rotate a set number of degrees. At .627", the TV shaft will move 52°. Depending on the tolerance in the software, this may set trouble codes if the adjustment is out of range. After installing the valve body in the vehicle, reset the TTVA by performing a Key On Engine Off cycle for 30 seconds. Turn ignition key off. Now the TTVA will be reset.

- f. Install OE boost valve, OE spring, Sonnax boost valve spring retainer (Figure 20) and OE cover plate.

Step 15 Install Intermediate Shaft Pilot & End Plug Kit

1. Disassembly

- a. Using a sheet metal screw, remove and discard the OE cup plug from the OE intermediate shaft (Figure 23).
- b. Using a steel rod (3/16" x 17"), drive the OE shaft pilot out from the cup plug end of the OE intermediate shaft, then discard pilot (Figure 24).

2. Installation (Figure 25)

- a. Clean the OE intermediate shaft bore thoroughly.
- b. Install the Sonnax cup plug by driving it into the OE intermediate shaft.

NOTE: An AXOD servo pin works well for this.

- c. Install the Sonnax shaft pilot into position by driving it in the front of the intermediate shaft. If the OE intermediate shaft does not have an internal stop to locate the pilot, position it so that .230"–.280" of the pilot protrudes out of the shaft.

Step 16 Install Output Pilot Bushing (Figure 26)

- a. Remove and discard pilot bushing.
- b. Press the Sonnax output shaft pilot bushing into the OE overdrive output shaft (Figure 27).

Step 17 Install 6-Tab Thrust Washers (Figure 28)

Step 18 Install Turbine Shaft Seals (Figure 29)

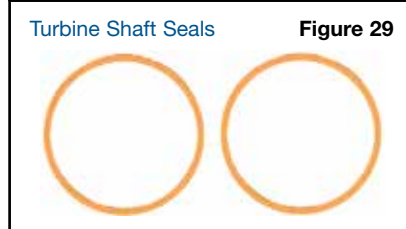
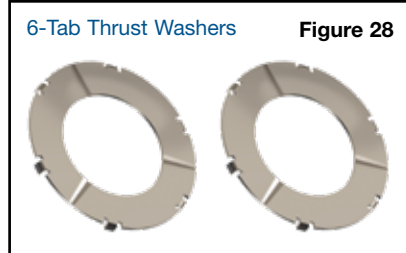
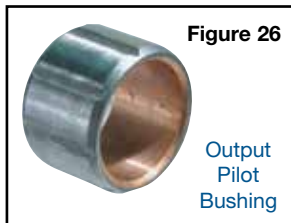
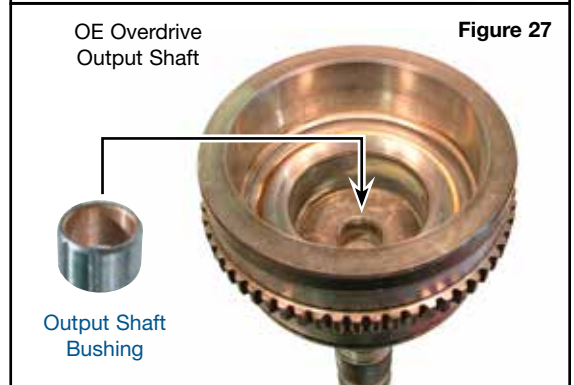
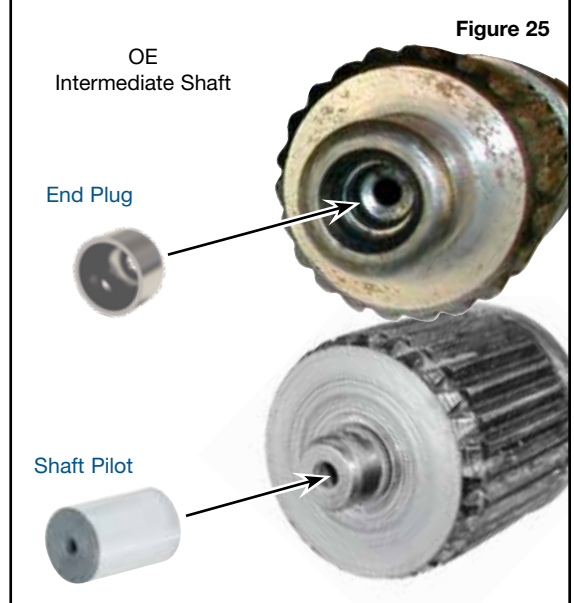
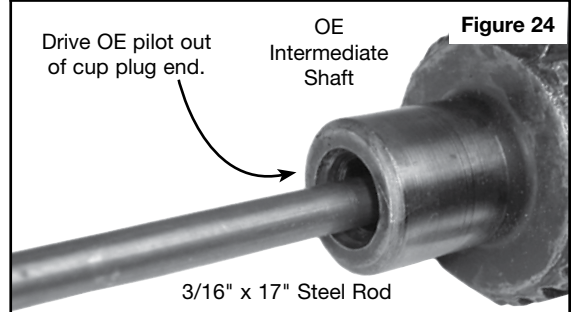
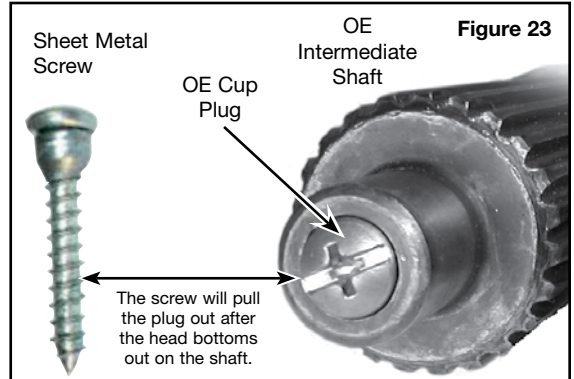



SONNAX 48RE CONVERTED VALVE BODY

Patent-pending Sonnax innovation converts plentiful early-model RE cores into premium-quality 48REs.

- 100% Tested to ensure pressure curves & timing match 48RE OE design
- Backed by Limited Lifetime Warranty
- Refurbished & improved with Sonnax parts
- Great for 46/47RE pressure & lockup upgrades



Part No. CHR135



**Ask your distributor for the Sonnax 48RE converted valve body.
Find more parts and remanufactured valve bodies at www.sonnax.com.**