

Case Repair Bearing



Part No.
22556-BRG

- Bearings (3)

NOTE: Instructions vary for early and late cases. Early cases have 1/8" NPT, while late cases have 1/4" NPT threads in the case for the cooler line fittings. Follow the procedure for your case to prevent machining into an oil passage.

Chrysler 46RE, 46RH, 47RE, 47RH, 48RE, A727

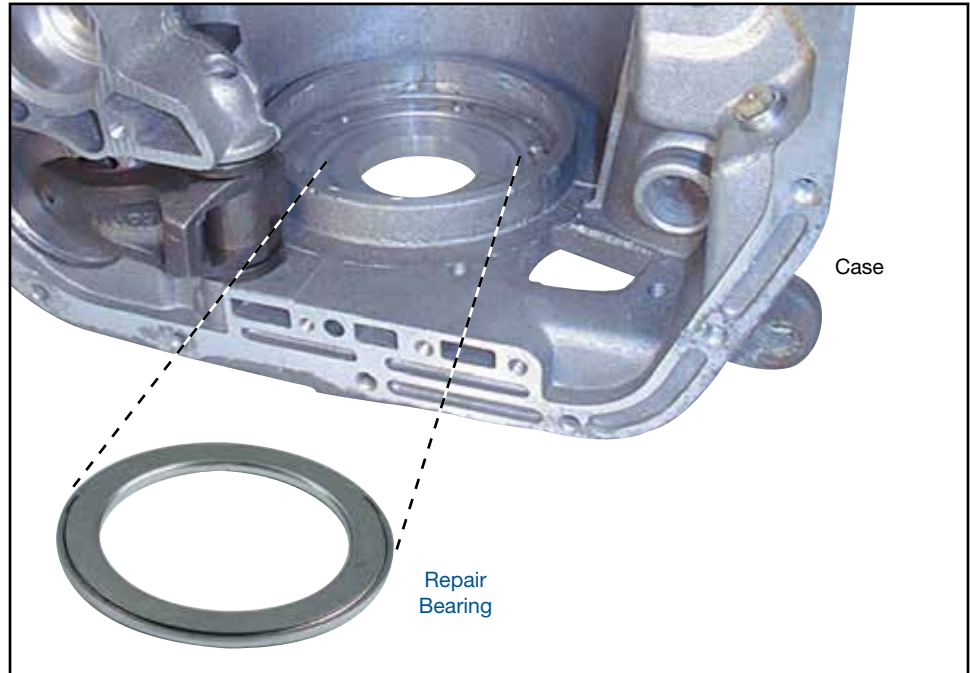

Installation & Assembly

1. Early 1/8" pipe cooler line fitting installation instructions

- Remove the roller clutch race from the case. Retain the race for re-installation.
- Attach the transmission case to the rotary table of a milling machine.
- Using an inch-reading test indicator, align the mill spindle within .005" TIR to the 2.200" diameter case bore, which locates the output shaft support.
- Mill a cavity 2.494–2.490" I.D. x 3.395–3.392" O.D. x .145–.150" deep below the bottom of the .070" step to accept the bearing (**Figure 1**).

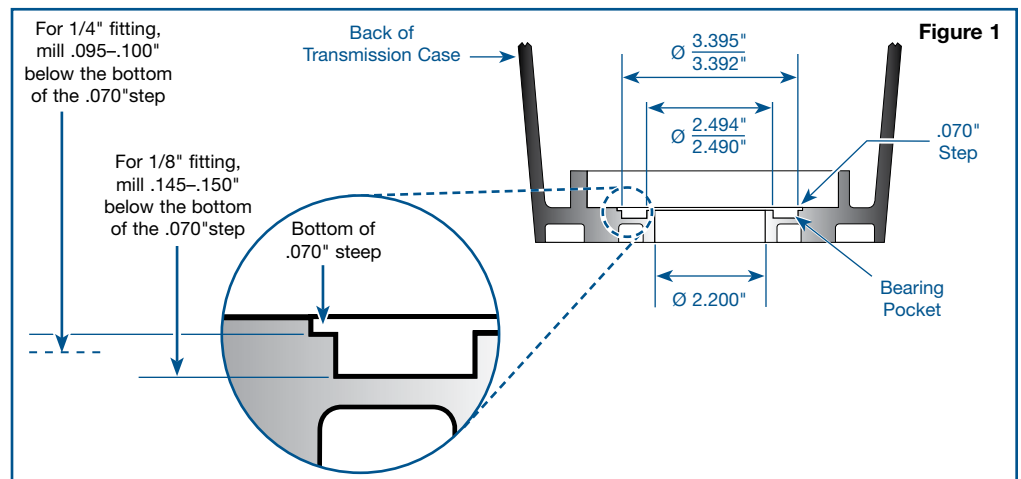

1. Early 1/8" pipe cooler line fitting installation instructions (continued)

- e. Place the bearing in the cavity. The bearing O.D. should be piloted by the O.D. of the milled cavity, and the bearing should sit flush to .005" above the .070" step in the bearing pocket.
- f. Install the previously removed roller clutch race and re-stake it in the case.

2. Late 1/4" pipe cooler line fitting installation instructions

- a. Remove the roller clutch race from the case. Retain the race for re-installation.
- b. Attach the transmission case to the rotary table of a milling machine.
- c. Using an inch-reading test indicator, align the mill spindle within .005" TIR to the 2.200" diameter case bore, which locates the output shaft support.
- d. Mill a cavity 2.494–2.490" I.D. x 3.395–3.392" O.D. x .095–.100" deep below the bottom of the .070" step to accept the bearing (**Figure 1**).
- e. Removing more material than specified from the back of the case on late units could cause damage to the oil passage.
- f. Place the bearing in the cavity. The bearing O.D. should be piloted by the O.D. of the milled cavity, and the bearing should sit .050–.055" above the .070" step in the bearing pocket.
- g. Remove .050" from the back of the reverse drum roller clutch race.



NOTE: The race has a hardness of Rockwell 60 and this will require a surface grinder or lathe with a good carbide bit.

- h. Install the previously removed roller clutch race and re-stake it in the case.