

Rear Sun Gear to Output Shaft Bearing Kit



Part No.
38208-01K

- Thrust Washer
- Bearing
- Shim, .015" thick

GM Powerglide[®]

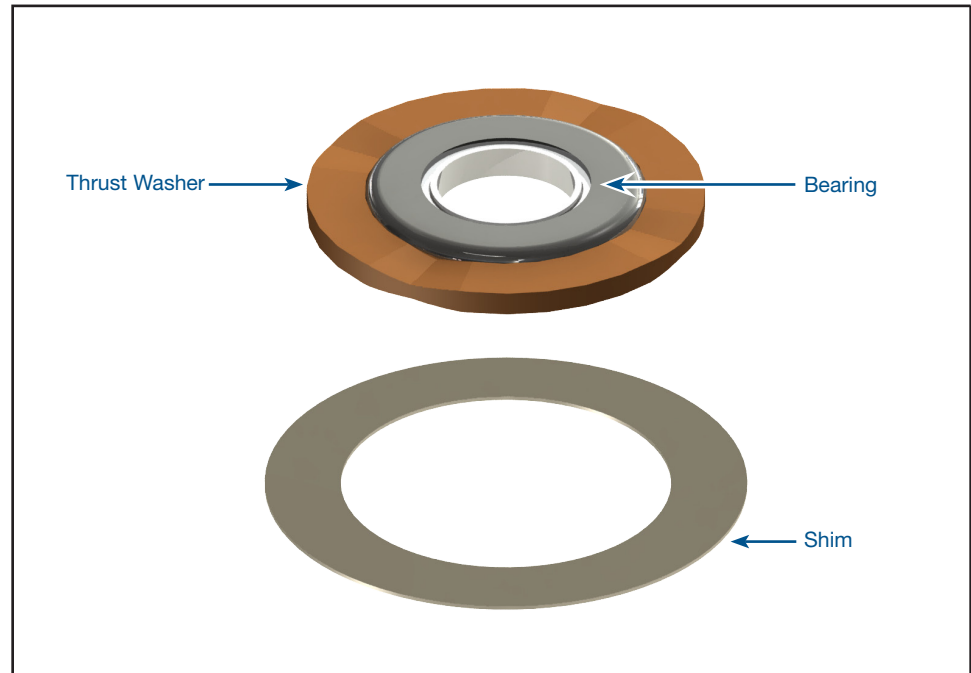

1. Dissassembly

Remove and discard the OE sun gear thrust washer.

2. Installation & Assembly

- Insert bearing into thrust washer.
- Install bearing and washer onto the input shaft, making sure the bearing is inserted in direction as shown (**Figure 1**).
- Finish assembly using normal procedures.
- Ensure .025" max endplay when using this bearing. The Sonnax .015" thick shim may be required and can be added between the output shaft and carrier-to-case thrust bearing.

NOTE: When using rear sun gears other than Sonnax current production, machining may be required as shown in **Figure 2** to allow clearance for bearing.

