

Line Pressure Booster Kit

Part No.

4L60E-LB2

- Large Ratio Boost Assembly Short
- Pressure Regulator Spring
- O-Rings (2)

Patent No. 6,619,323

NOTE: Fits late-style (short) boost sleeve, 1.810" length.

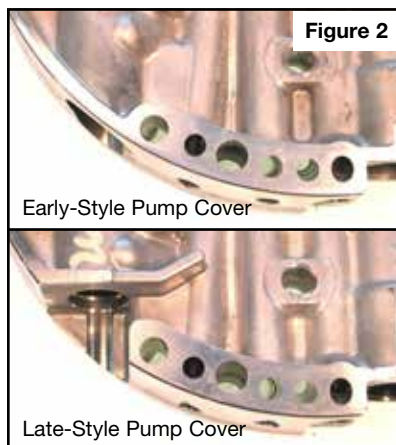
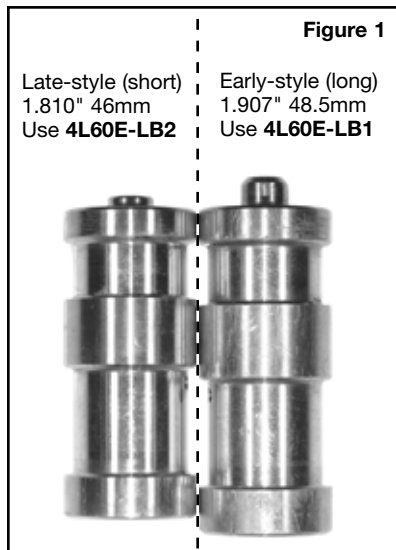

GM 4L60-E, 4L65-E, 4L70-E

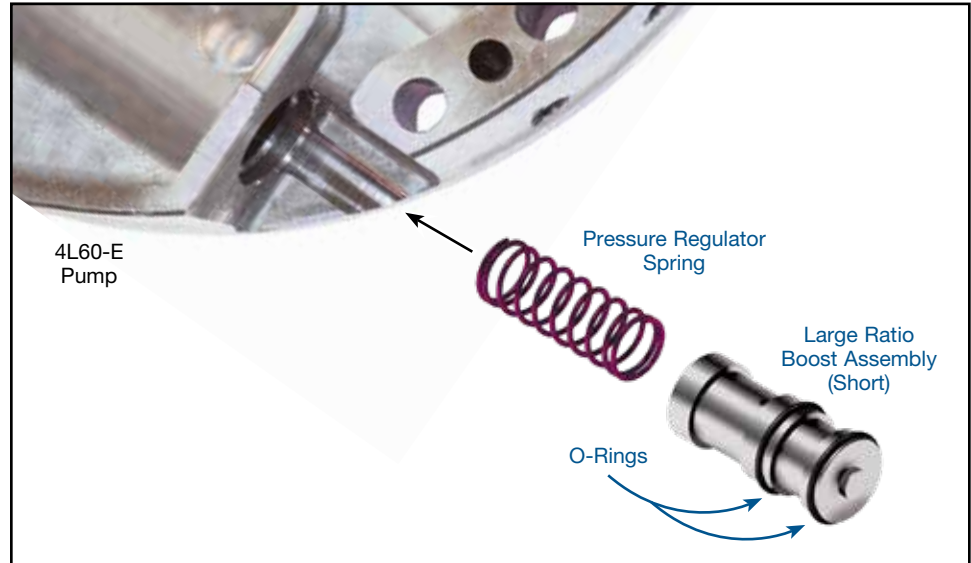

1. Verify Correct Boost Valve Application

Before installing Sonnax line pressure booster kit, compare length of the OE boost sleeve to Sonnax sleeve. Overall lengths must be the same. Most early-style pump bodies will use the long boost assembly (**Figures 1 and 2**). Some late production, early-style pump covers will use the short boost assembly (**4L60E-LB2**), even though the casting number and all other features are identical. In most circumstances, comparing the original boost sleeve to the replacement is all that is required for verification (**Figures 1 and 2**).

If you have a pump cover that is missing the boost sleeve it is possible to verify which length sleeve belongs in the bore by measuring from the very inner point of the main pressure regulator valve bore to the inner edge of the retaining ring groove. The distance for the long boost assembly is 4.740", and for the short boost assembly is 4.643".

2. Disassembly

- Remove OE retainer and set aside for reuse.
- Remove and discard OE boost valve and sleeve.
- Remove OE bumper spring and set aside for reuse.
- Remove and discard OE large-diameter pressure regulator spring.

3. Bore Preparation

O-rings included in this kit provide extra insurance toward preventing cross leaks and should always be installed.

- Carefully inspect snap ring grooves, feed holes or bore edges and de-burr if necessary to reduce cutting. A non-abrasive tool such as a radial wire brush (**Figure 3**) works best, but the bore should always be thoroughly cleaned after any de-burring.
- Place the two O-rings into the grooves on the boost sleeve, roll sleeve over bench to resize the O-rings, then pre-lube O-rings. Sonnax Slippery Stick™ (**O-LUBE**) or Door Ease® are ideal for this purpose.

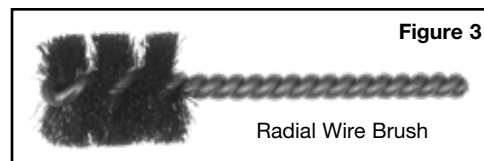

4. Installation

- Install OE small bumper spring and Sonnax pressure regulator spring.
- With open end toward the two springs, carefully insert Sonnax valve/sleeve assembly into pump cover, just far enough to reinstall OE retaining ring.

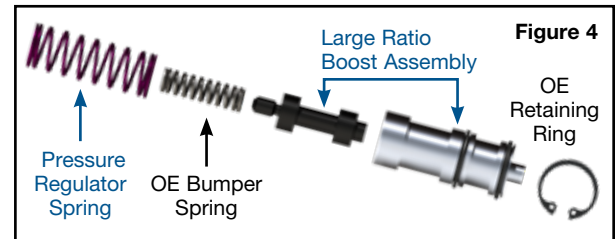

The Prescription for Optimum Pressure

Stronger pressure regulator springs raise pressure equal amounts at both idle and maximum load. Many aftermarket “kit” springs are a compromise, raising pressure too much at idle and not enough at maximum loads (A in graph). Larger boost valves, on the other hand, have a progressive effect on pressure, changing the rate of pressure increase (B in graph).

The Sonnax large ratio boost valves and stronger pressure regulator springs are designed to work together. This is an ideal combination: smooth engagements and lower load on the pump at idle, but a greater increase in pressure as the transmission is worked harder.

For a more in-depth look at raising line pressure, read *The Prescription for Optimum Pressure* in the Sonnax online technical library at www.sonnax.com.

Pump Tech

Good Pressure Depends on a Good Pump

Verify Pump Specifications

Excess clearance equals low pump volume and pressure.

Rotor, slide and vanes

.0005" to .002" Check with feeler gauge and straight edge over pump face, or with Plastigauge and bolt complete pump together.

Too Loose = low pressure. Too Tight = no line rise, slide is stuck. To check, remove all pump parts and seals, assemble halves with just the pump slide and shake. You should hear pump slide moving inside.

Check for Wear

- If pivot is worn, replace with Sonnax pivot pin 65797.
- If vane has visible wear, replace with Sonnax pump vane 1280.

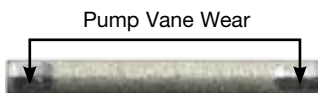

Shift Tech

For detailed information on drilling separator plate orifices, read *Drilling Orifices the Smart Way* in the Sonnax online technical library at www.sonnax.com.

