

Input Drum Reinforcement Kit



Part No.
77733-02K

- Reinforcement Sleeve
- Overrun Piston Inner Seal

GM 4L60, 4L60-E, 4L65-E, 4L70-E

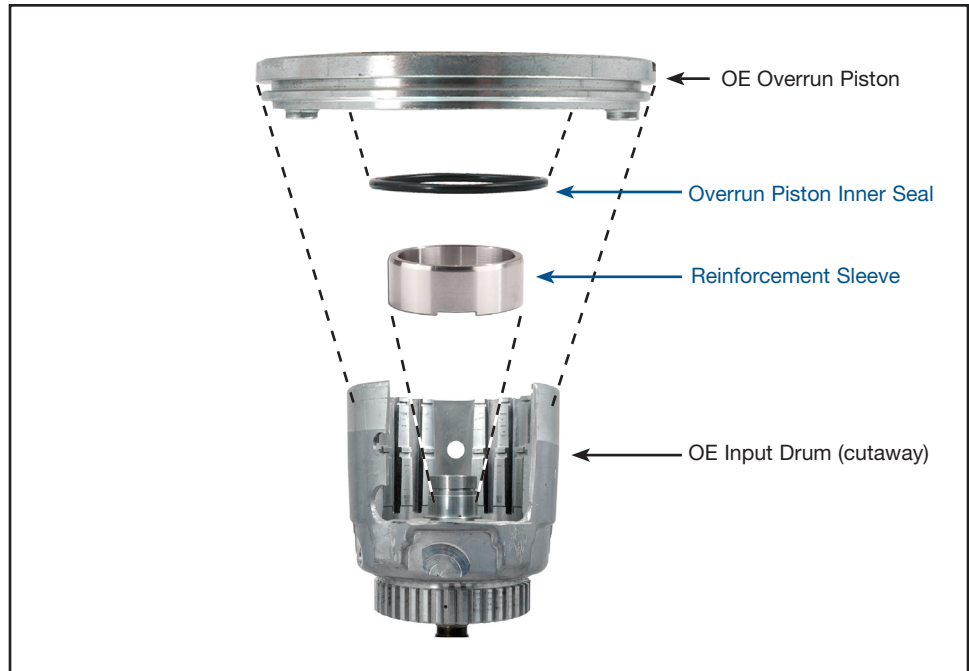

1. Sleeve Installation

- Inspect the drum for cracks or damage. This sleeve will not repair a cracked drum. Set the input drum into a hydraulic press (or arbor press). Use an appropriate sized tube or a spare (not to be reused) 4L60 stator shaft with the selective spacer (with bearing left out) to support the aluminum housing directly under the area being pressed on. A 4L60-E rear sun gear works well to drive the sleeve on.



CAUTION: Not supporting the drum directly under the sleeve can result in damage to the shell.

- Refer to photo above. Clean the reinforcement sleeve area and take note of the overrun clutch feed hole location.
- Thoroughly clean the reinforcement sleeve.
- Coat the inside of the sleeve with green Loctite® 609. Align the notch in the sleeve with the over run feed hole in the housing (**Figure 1**). Set the sleeve into position on the input drum, keeping the notch in the sleeve aligned with the over run feed hole in the housing.

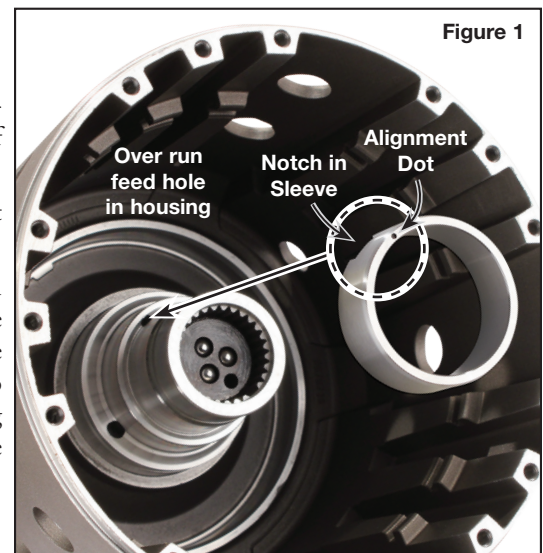

Figure 1

1. Sleeve Installation (continued)

- e. Using the press, install sleeve until just barely seated. Do not seat sleeve with the full force of the press since excessive pressure will ruin the housing. Do NOT hammer or pound the sleeve into place.
- f. Verify over run feed hole is not blocked by the sleeve.

2. Piston Modification

- a. The kit requires an early-style cast aluminum OE overrun piston in good working order.



NOTE: Requires '96-earlier aluminum forward piston or Sonnax billet forward piston 77764-01, cannot be used with stamped steel forward piston.

- b. Fixture the overrun piston in a lathe and indicate the I.D. so it is running true.
- c. Bore the I.D. out $\text{Ø}1.834"/1.829"$. Radius both sides of the seal groove with $R.005"/.015"$ radii. Make sure to deburr both outer edges (**Figure 2**).
- d. Thoroughly clean the piston of any chips, debris or cutting fluid.

3. Input Drum Assembly

- a. Use the modified early-style cast-aluminum OE overrun piston with an early-style cast-aluminum forward piston. The late-model stamped steel forward piston cannot be used (**Figure 3**). If you are rebuilding a late-model unit that has a stamped steel forward piston you must obtain an early-style cast-aluminum forward piston.



NOTE: A recommended measure before installation is to seat the checkball in the overrun piston with a small punch.

- b. If using a late-model return spring assembly (identified by two spring retainers on both ends of the springs) remove and discard the lower spring retainer (**Figure 3**). Although not required, the early-style return spring used with OE aluminum pistons is about 10% stronger and is preferred for high RPM applications.
- c. Assemble input drum as usual.

