

1-2 Accumulator Bore Sleeve Kit

Part No.
96513K

- Sleeve
- Piston
- O-Ring

Viton®

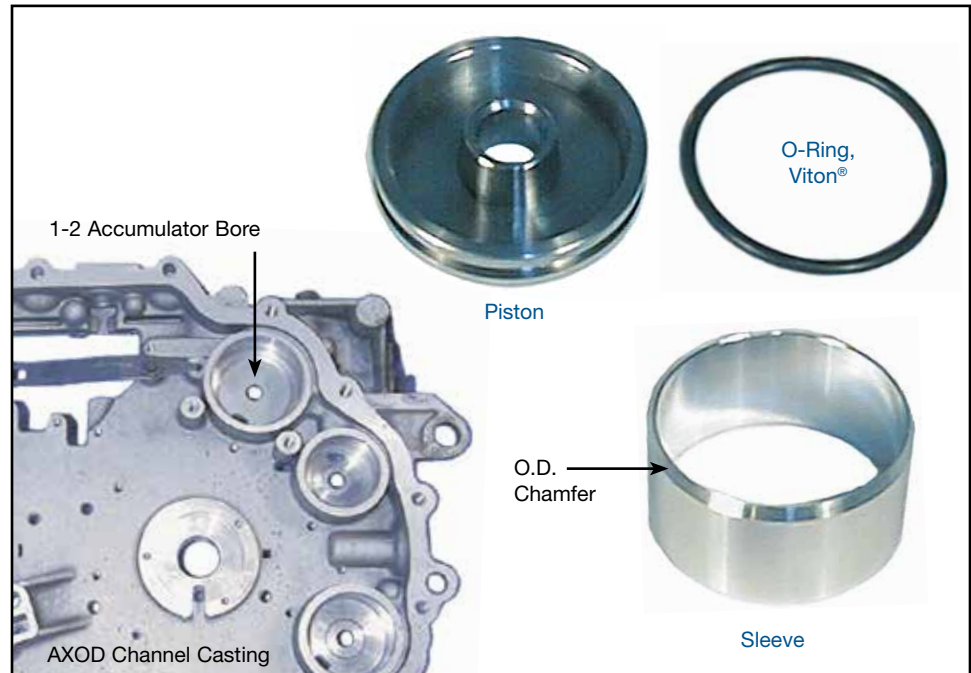

Ford AX4S, AXOD, AXODE

1. Disassembly

- Remove any burrs or raised areas from the accumulator bore.
- Thoroughly clean out any debris or grease.

2. Installation & Assembly

- Apply Loctite 609® to Sonnax sleeve.
- Place the O.D. chamfer end of Sonnax sleeve into the 1-2 accumulator bore and press into sleeve until it makes contact with the bottom.
- Install Sonnax O-ring into Sonnax piston, then install into Sonnax sleeve.
- Reinstall OE pin and spring.

