

GM 400, 4L80-E, 4L85-E

Heavy Duty Case Bushing Kit

Part No.
34006-SPB

- Bushing
- Thrust Bearing
- Shim (2) .010"
- Shim (2) .015"



1. Disassembly

- a. Remove OE case bushing from the transmission case. Check the case bore for burrs, deburr the leading (inward) edge as needed.

NOTE: If the OE bushing has spun, measure the case bore. For an ideal fit, the bore should not measure more than 2.1285" in diameter.

2. Assembly

- a. Press Sonnax no-walk bushing into the case bore from inside the transmission so bushing flange is seated on the transmission case.
- b. Discard OE 3 tab selective washer and 4 tab thrust washer.
- c. Two .010" and two .015" Sonnax shims are included to set the rear unit endplay in accordance with OE specifications. These shims allow adjustment in .005" increments covering the common range of OE selective washers. Install the required combination of selective shims around the bushing's flange and against the face of the case.

Rear End Play Specifications:

- **4L80-E** .005–.025"
- **TH400** .007–.019"

- d. Install Sonnax thrust bearing around the bushing's flange and against the shims in proper orientation (**Figure 1**).

NOTE: On some applications, the output shaft may be snug during re-assembly. Tap on the shaft at spline area to re-form the bushing high spots.

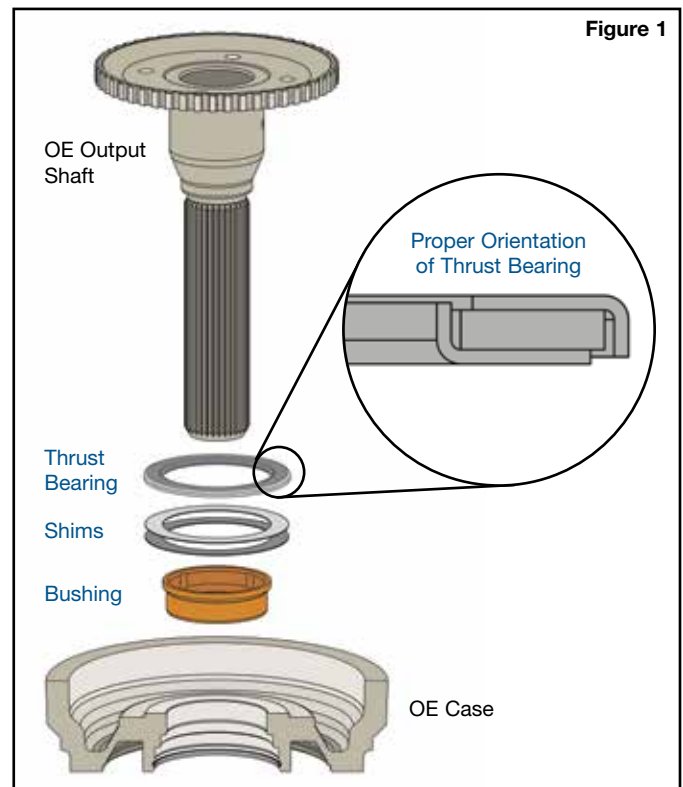

Figure 1