

Oversized Pressure Regulator & Boost Valve Kit



Part No.
76948-17K

- Pressure Regulator Valve
- Boost Valve
- Boost Sleeve

NOTE: Fits '96-later only. Sonnax oversized pressure regulator valve is designed for use ONLY with included Sonnax oversized boost valve assembly.

NOTE: Two Reaming Options Available.

Reaming Option 1:

Tool Kit

Part No.
F-76948-TL

- Reamer
- Reamer Jig
- Guide Pin

NOTE: Sonnax "F-Tool" kits designed to service a specific bore require the VB-FIX, a self-aligning valve body reaming fixture. More information and instructions can be found online at www.sonnax.com.

Reaming Option 2:

Tool Kit

Part No.
76948-TL4

- Reamers (2)

NOTE: This is a bench tool kit and does not require VB-FIX.

After reaming, use Bore Sizing Tool **76948-BST** (sold separately) to provide exact sizing and improved bore finish.

Ford 4R70E, 4R70W, 4R75E, 4R75W, AODE

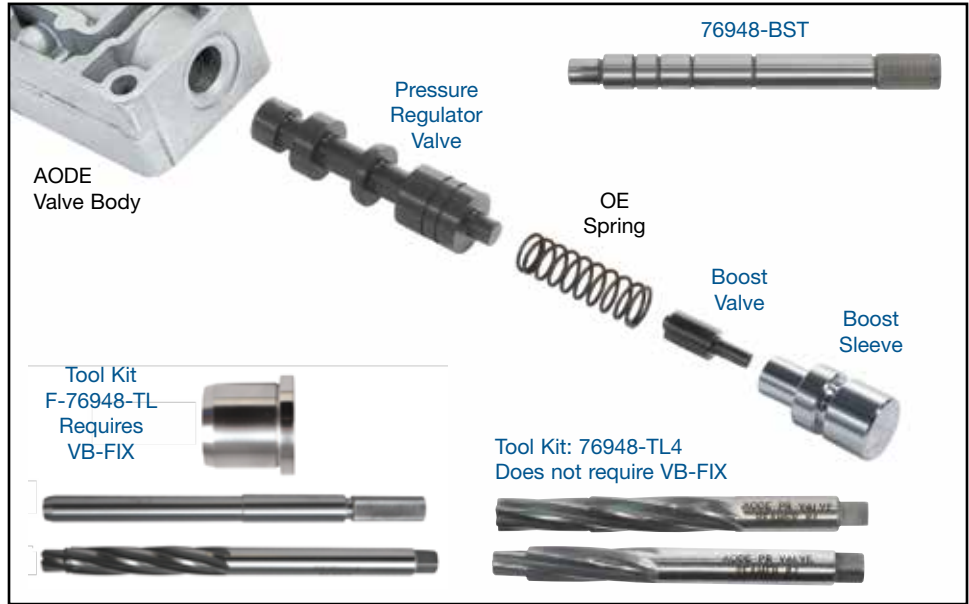

Figure 1

1. Identify Early vs. Late Valve Body (Figure 1)

2. Disassembly

- Remove OE valve train from pressure regulator bore.
- Set aside OE pressure regulator spring and retainer for reuse.
- Discard OE boost valve/sleeve and pressure regulator valve.

3. Bore Reaming

NOTE: Tool kit **76948-TL4** reaming instructions are listed below. Please visit www.sonnax.com for **F-76948-TL** tool kit reaming instructions.

- Clean bore thoroughly in solvent tank.
- Generously lubricate bore and reamer #1 with cutting fluid (i.e. Mobilmet S-122, Lubegard® Bio-Tap, Tap Magic™, etc.). For best results, provide a continuous flow of cutting fluid during the reaming process.

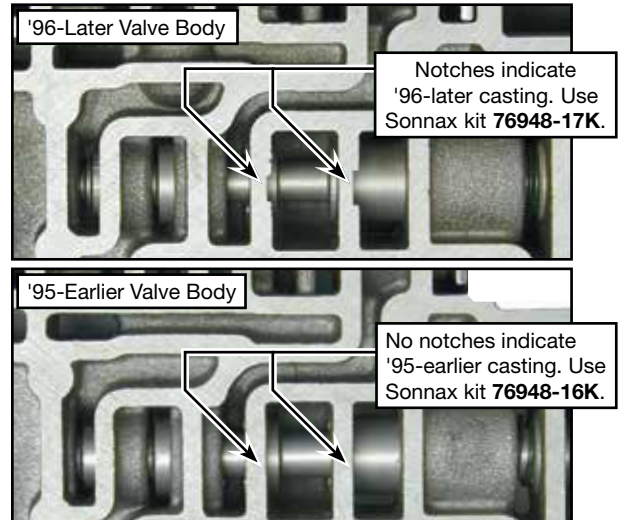

Figure 2



- c. Gently insert reamer #1 into bore until cutting tip contacts the first land to be reamed.
- d. Use a loose-fitting reamer socket and a wobble adapter to ream the bore. Reamer can be turned using a speed handle or with a low-RPM, high-torque drill regulated to a maximum of 200 RPM. The reaming actions must be clockwise in smooth and continuous motion at 60-200 RPM. Continue reaming until the reamer stop is reached.
- e. Using low air pressure, blow the chips free before removing reamer.
- f. To remove reamer, turn clockwise while slowly pulling outward.
- g. Repeat steps a-f using reamer #2.

4. Finish & Clean-Up

- a. Examine the bore after cleaning for surface finish, debris and burrs. Flashing and burrs on the exit side of land and in bores must be carefully removed. A small piece of Scotch-Brite™ material attached to a wire and powered with a drill motor is ideal for the task. However, Scotch-Brite™ is a very abrasive material and all residual Scotch-Brite™ debris must be removed afterward to ensure particles do not migrate or remain embedded in the surface. Cleaning this material out should involve several progressive steps using solvent on a lint-free rag.
- b. Clean the reamer after each use and store in its protective tube.

5. Bore Sizing Tool



NOTE: The end of the bore sizing tool has been tapped to allow use of a slide hammer with a 5/16-18 UNC threaded adapter.

- a. Insert bore sizing tool into reamed pressure regulator bore. Press into bore until tool bottoms out.
- b. Remove sizing tool and check to see if Sonnax pressure regulator valve and boost sleeve move freely within bore.
- c. If Sonnax valve and/or sleeve do not move freely, reinstall bore sizing tool and tap tool back and forth using a hammer and screwdriver inserted through the ports and into tool grooves (**Figure 3**). Repeat process until valve strokes freely.

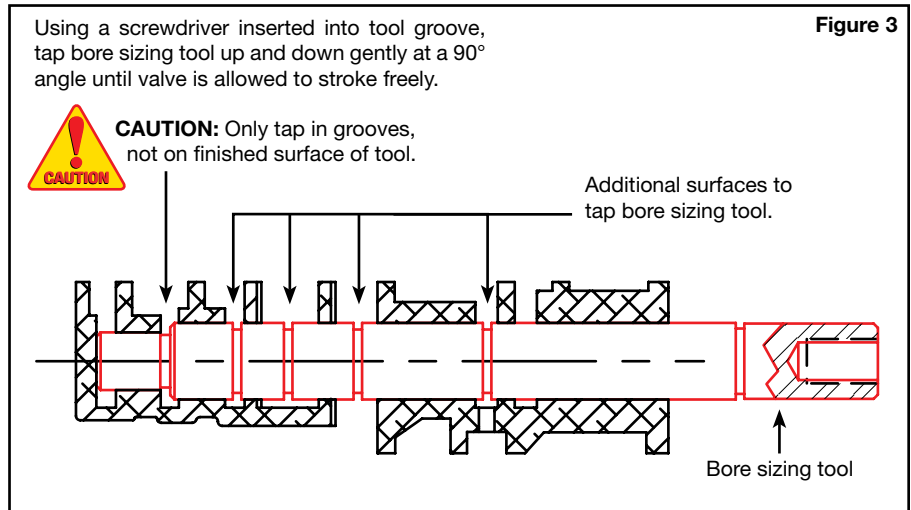

Figure 3



CAUTION: Only tap in grooves, not on finished surface of tool.

6. Installation & Assembly

- a. Identify valve body and valve application (**Figure 1**).
- b. Lubricate Sonnax pressure regulator valve prior to installing.
- c. Install Sonnax pressure regulator valve, smaller diameter first.
- d. Reinstall OE pressure regulator spring.
- e. The small OE boost spring was eliminated in later applications and is not required. If your application originally had the spring, it may be reinstalled into the Sonnax boost assembly if desired. If installed, slightly quicker Reverse line rise will result.
- f. Verify Sonnax boost valve is assembled with smaller diameter stem into sleeve first.



NOTE: Only the oversized boost valve and sleeve supplied in this kit should be used.

- g. Install Sonnax boost sleeve assembly into bore, just far enough to allow reinstallation of OE retainer.

7. Final Testing

Vacuum testing at the port(s) indicated holds the recommended minimum 18 in-Hg (**Figure 4**).

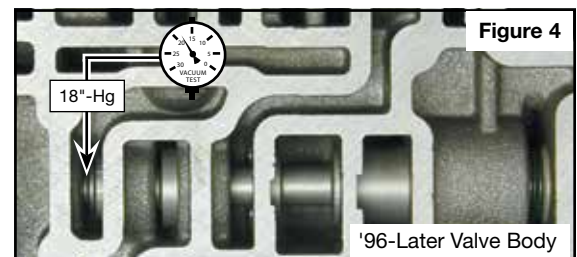

Figure 4