

### Alignment Hole Key

Red ● = Alignment Pins / Black ● = Push Pin Locations / Blue ● = Optional Bolt Locations

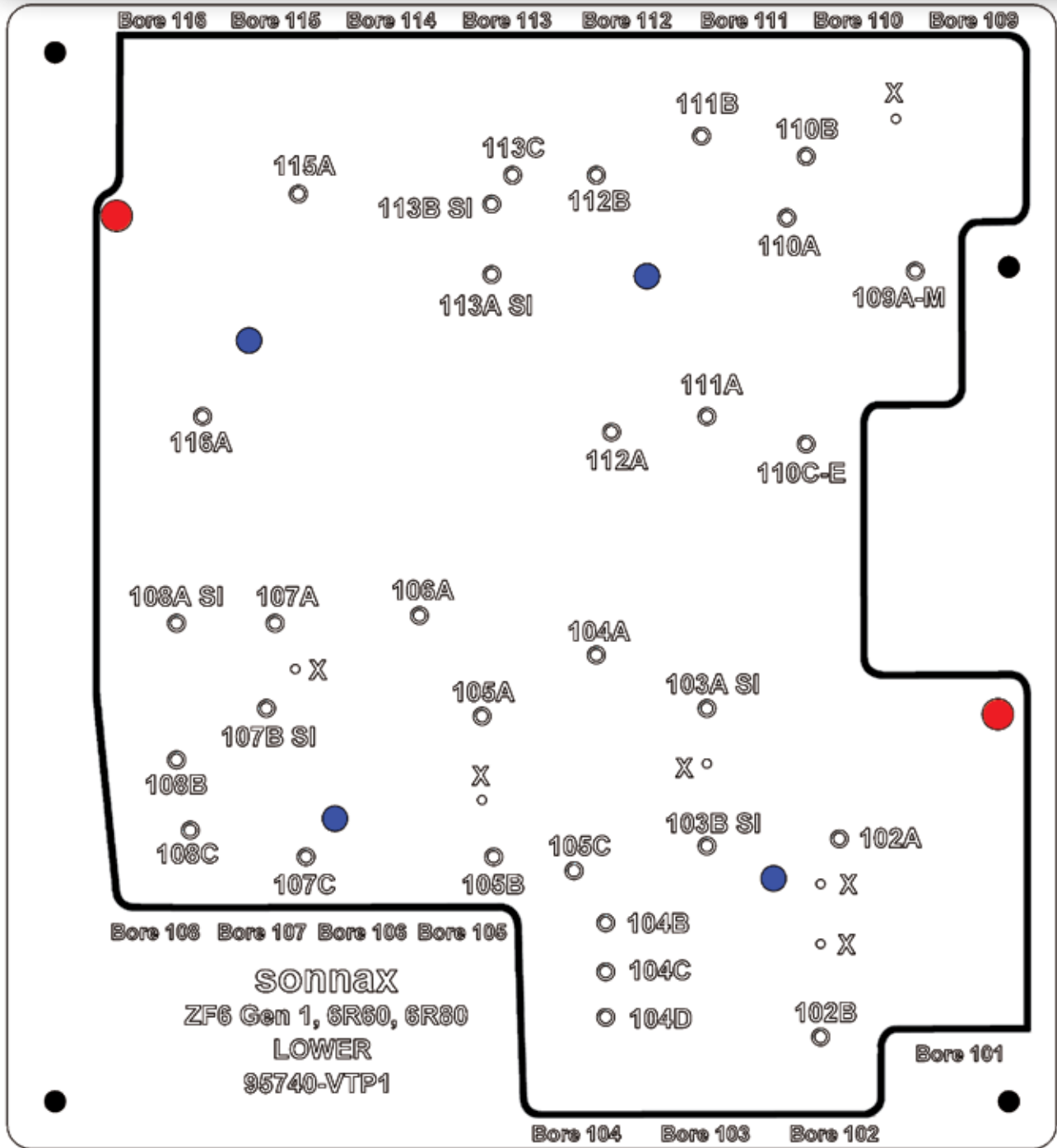

**NOTES:** Cannot be used with 053 separator plate applications.

E-Shift are units with NO manual valve. M-Shift are units with manual valve. "X" orifice locations on plate are for air inlet and do not require testing.

**PART NUMBER 95740-VTP1**

**Alignment Hole Key**

Red ● = Alignment Pins / Black ● = Push Pin Locations / Blue ● = Optional Bolt Locations

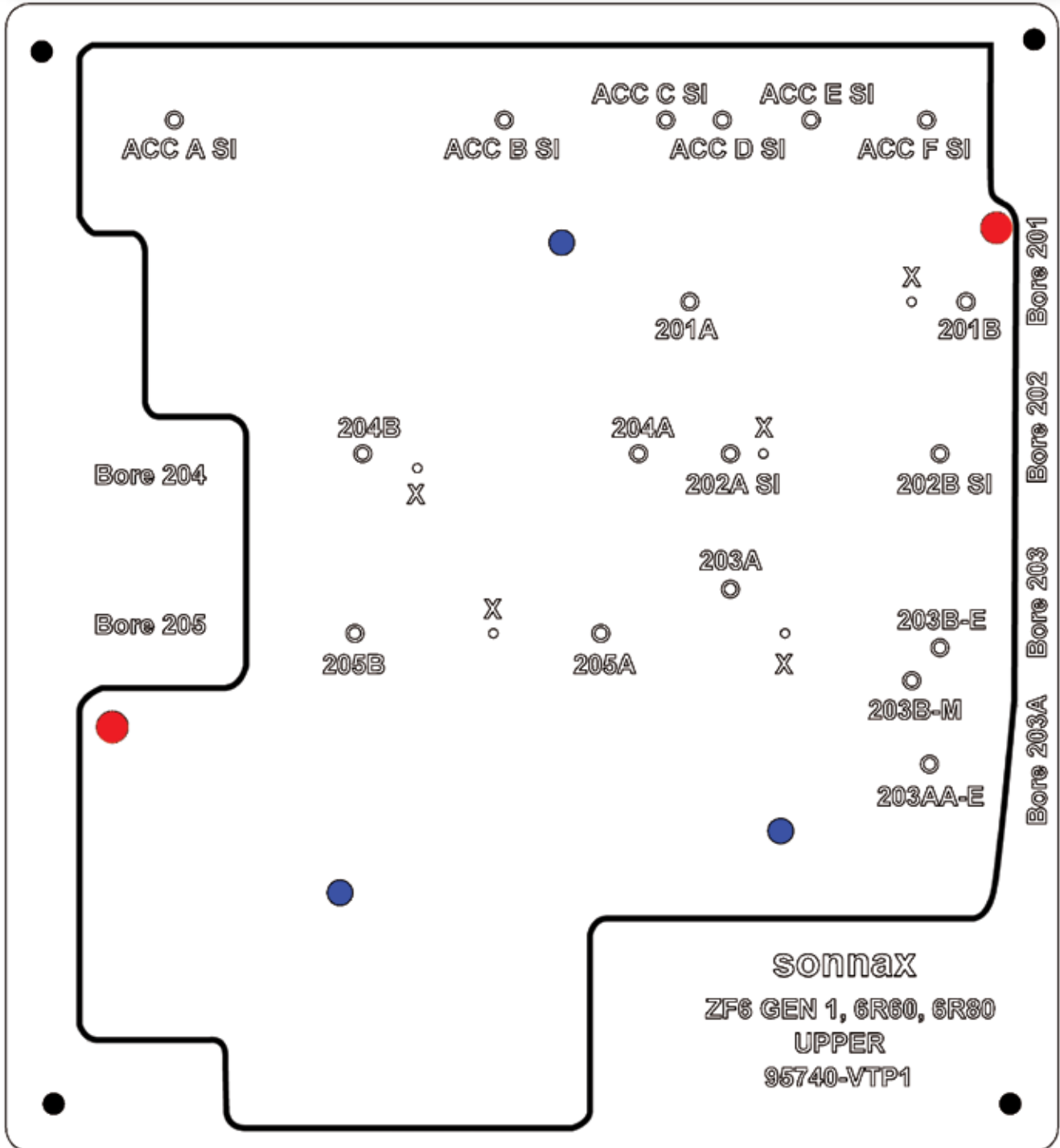

**NOTE:** E-Shift are units with NO manual valve. M-Shift are units with manual valve. "X" orifice locations on plate are for air inlet and do not require testing.

## Vacuum Test Plate Kit

### Part No.

**95740-VTP1**



- Lower Plate
- Upper Plate
- Seals (2)
- Push Pins (12) 4 Extra
- Alignment Pins (4)
- Bolts (4)
- Washers (4)
- Wing Nuts (4)
- Test Spring
- Test End Plug



**NOTE:** Cannot be used on 053 separator plate applications.

## Vacuum Test Stand Kit

### Part No.

**VACTEST-01K**

- Vacuum Test Stand
- Test Plate
- Vacuum Plate Sealing Pad
- Vacuum Test Foam Pad
- Push-to-Connect Fitting
- Assorted Testing Tips (6)
- Testing Tip Adapter Tube
- Flexible Tubing
- Flared Tubing with Flared Nut

## Instructions

### 1. Assembly

- Ensure vacuum test plate and seal are both clean and free of debris.
- Install two alignment pins into plate at indicated threaded holes. Thread into non-engraved side of plate (**Figure 1**).
- Place seal onto non-engraved side of plate, aligning orifice holes. Remove any entrapped air between plate and seal by peeling seal up at plate edge. Gradually place seal back on plate from center toward edge.
- Push plastic push pins into seal and plate from seal side, just far enough for head to lightly contact seal.

### 2. Testing

- Place assembled vacuum test plate over casting, using engraved casting outline as guide. Alignment pins should enter casting bolt holes.
- Using **VACTEST-01K** (sold separately) and small vacuum tip, vacuum test at numbered orifices on plate. These numbers correspond to the bore numbers called out in the exploded view of the valve body on page 6. The chart on page 8 provides descriptions of individual circuit checked and space to document actual vacuum readings and minimum vacuum standards.

**NOTE:** Vacuum Test Data Sheet on page 7 can be used to establish minimum vacuum standards at individual bore locations.

- Light fingertip pressure may need to be applied on plate during testing. Included bolts, washers and wing nuts can be used at indicated bolt locations for firmer seal, but are not required. If used, place bolts through casting, seal and plate from the back of casting. Tighten wing nut against plate, finger-tight only.

### 3. Cleaning

Seal and plate can be cleaned as needed with mild soap and water to remove debris.

### 4. What should my vacuum test results be?

While a properly calibrated and maintained test stand will give consistent vacuum reading results for a specific circuit and amount of wear, evaluating these results requires establishing your own pass/fail criteria. Variables which influence vacuum readings are the number of spools tested in a captive circuit, spool diameter size and contact length of the spool within the bore.

Pass/Fail standards are specific to your setup and process, but they also must be based on your experience, quality sensitivity, warranty concerns and cost/pricing structure. Sonnax recommends that you keep a record of vacuum results for each valve body at each tested circuit/port location. This lets you compare results over time to help determine for your shop what an acceptable vacuum reading is for each circuit/port location.

A chart specific to this application is provided in this booklet indicating valve and circuit checked at each orifice location. Room is provided to record results and compare to your minimum vacuum standard. A generic vacuum test data sheet also is provided that can be used to evaluate multiple cores to establish your minimum vacuum standard. These documents can be printed or downloaded and stored on your computer.

Figure 1

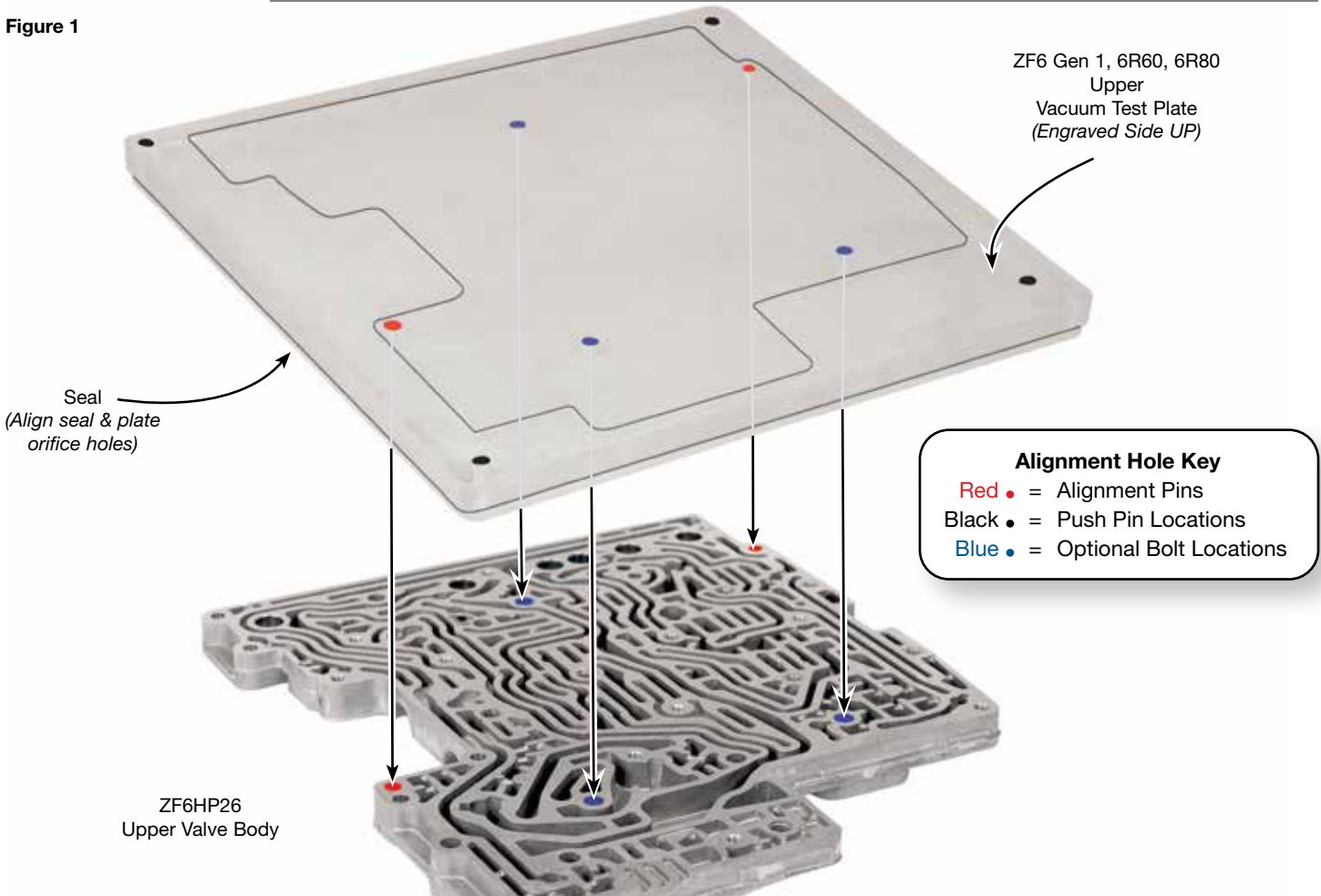

**Critical Wear Areas & Vacuum Test Locations**

**ZIP** Drop-In Zip Valve™ Parts Available

**ZF6-6R60-ZIP** Zip Kit® Available

**NOTE:** OE valves are shown in rest position and should be tested in rest position unless otherwise indicated. Test locations are pointed to with an arrow. Springs are not shown for visual clarity. Low vacuum reading indicates wear and Sonnax parts are noted for replacement.

**Upper Valve Body • Jaguar ZF6HP26, M-Shift Shown**

**NOTE:** The D2 valve is not used on 2011-Later 6R80. The bore is completely empty.

**Accumulator Pistons**

- Downshift clunk
- Firm shifts
- Erratic EDS solenoid control/EDS codes

**Replace with Sonnax Part No. 95740-15K**  
Patent No. 8,794,108

**Clutch D1 Control Pressure Regulator Valve**

- Bumpy 1-2 upshift
- 2-1 Downshift flare or neutral
- EDS 3 control code

**Replace with Sonnax Part No. 95740-08K** Requires F-95740-TL8 & VB-FIX

Test accumulator pistons inverted and off center.

OE accumulator pistons should be flush with or approximately .030" lower than the casting surface. It is common for the rubber insert to lose tension. Each of these pistons can be vacuum tested from the exhaust hole on the opposite side of the casting.

**Clutch C Regulator Valve**

- 2nd & 6th Slip
- Clutch failure
- Poor shift quality
- Ratio errors

**Replace with Sonnax Part No. 95740-40K** Requires F-95740-TL40 & VB-FIX

**NOTE:** Does not fit 2011-Later. See note on page 6.

# Critical Wear Areas & Vacuum Test Locations



Drop-In Zip Valve™  
Parts Available



ZF6-6R60-ZIP  
Zip Kit® Available

**NOTE:** OE valves are shown in rest position and should be tested in rest position unless otherwise indicated. Test locations are pointed to with an arrow. Springs are not shown for visual clarity. Low vacuum reading indicates wear and Sonnax parts are noted for replacement.

## Lower Valve Body • Jaguar ZF6HP26, M-Shift Shown

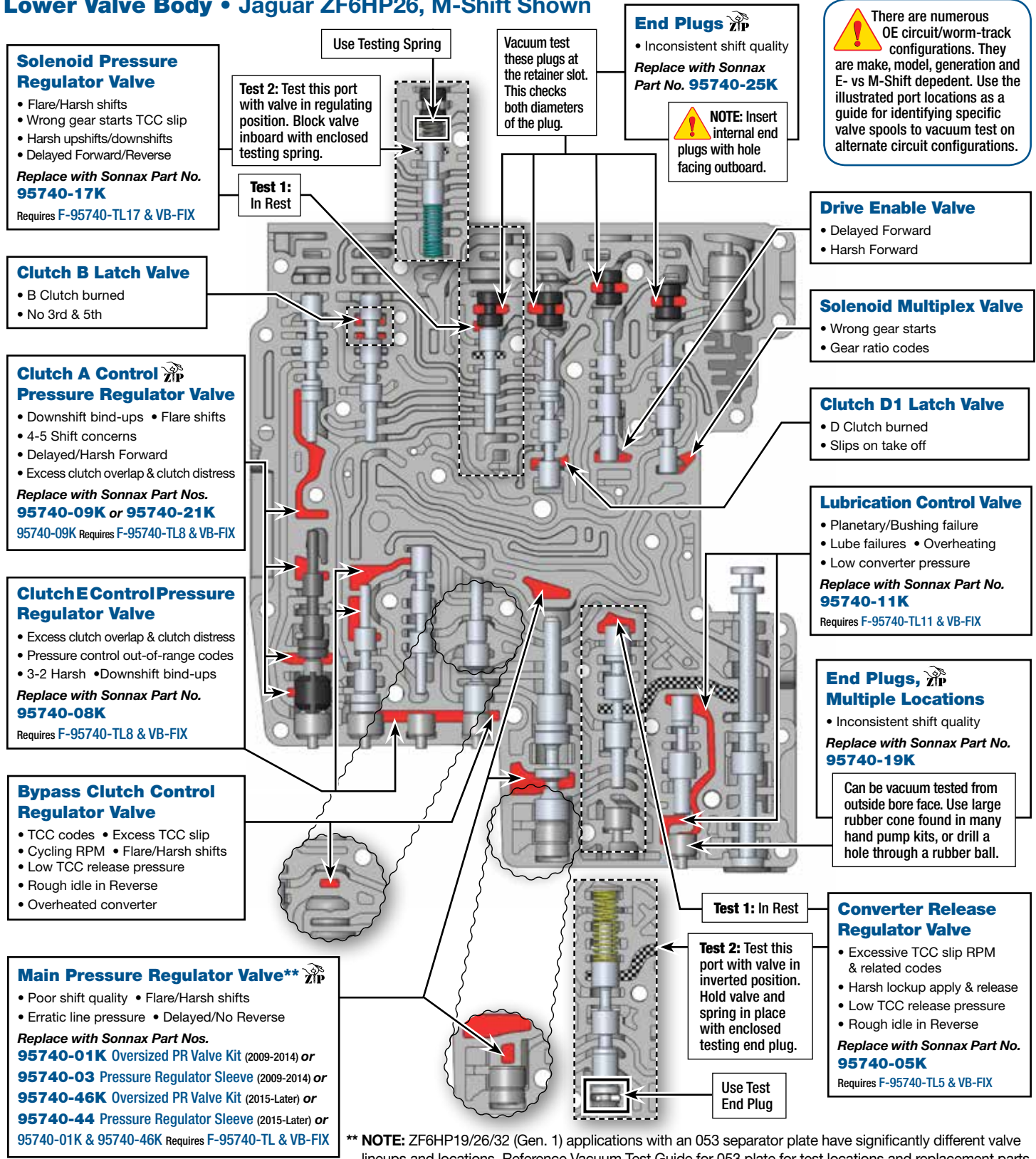

**Solenoid Pressure Regulator Valve**

- Flare/Harsh shifts
- Wrong gear starts TCC slip
- Harsh upshifts/downshifts
- Delayed Forward/Reverse

Replace with Sonnax Part No. **95740-17K**  
Requires F-95740-TL17 & VB-FIX

**Clutch B Latch Valve**

- B Clutch burned
- No 3rd & 5th

**Clutch A Control Pressure Regulator Valve**

- Downshift bind-ups • Flare shifts
- 4-5 Shift concerns
- Delayed/Harsh Forward
- Excess clutch overlap & clutch distress

Replace with Sonnax Part Nos. **95740-09K or 95740-21K**  
95740-09K Requires F-95740-TL8 & VB-FIX

**Clutch E Control Pressure Regulator Valve**

- Excess clutch overlap & clutch distress
- Pressure control out-of-range codes
- 3-2 Harsh • Downshift bind-ups

Replace with Sonnax Part No. **95740-08K**  
Requires F-95740-TL8 & VB-FIX

**Bypass Clutch Control Regulator Valve**

- TCC codes • Excess TCC slip
- Cycling RPM • Flare/Harsh shifts
- Low TCC release pressure
- Rough idle in Reverse
- Overheated converter

**Main Pressure Regulator Valve\*\***

- Poor shift quality • Flare/Harsh shifts
- Erratic line pressure • Delayed/No Reverse

Replace with Sonnax Part Nos.  
**95740-01K Oversized PR Valve Kit (2009-2014) or**  
**95740-03 Pressure Regulator Sleeve (2009-2014) or**  
**95740-46K Oversized PR Valve Kit (2015-Later) or**  
**95740-44 Pressure Regulator Sleeve (2015-Later) or**  
**95740-01K & 95740-46K** Requires F-95740-TL & VB-FIX

**End Plugs**

- Inconsistent shift quality

Replace with Sonnax Part No. **95740-25K**

**NOTE:** Insert internal end plugs with hole facing outboard.

There are numerous OE circuit/worm-track configurations. They are make, model, generation and E- vs M-Shift dependent. Use the illustrated port locations as a guide for identifying specific valve spools to vacuum test on alternate circuit configurations.

**Drive Enable Valve**

- Delayed Forward
- Harsh Forward

**Solenoid Multiplex Valve**

- Wrong gear starts
- Gear ratio codes

**Clutch D1 Latch Valve**

- D Clutch burned
- Slips on take off

**Lubrication Control Valve**

- Planetary/Bushing failure
- Lube failures • Overheating
- Low converter pressure

Replace with Sonnax Part No. **95740-11K**  
Requires F-95740-TL11 & VB-FIX

**End Plugs Multiple Locations**

- Inconsistent shift quality

Replace with Sonnax Part No. **95740-19K**

Can be vacuum tested from outside bore face. Use large rubber cone found in many hand pump kits, or drill a hole through a rubber ball.

**Converter Release Regulator Valve**

- Excessive TCC slip RPM & related codes
- Harsh lockup apply & release
- Low TCC release pressure
- Rough idle in Reverse

Replace with Sonnax Part No. **95740-05K**  
Requires F-95740-TL5 & VB-FIX

**\*\* NOTE:** ZF6HP19/26/32 (Gen. 1) applications with an 053 separator plate have significantly different valve lineups and locations. Reference Vacuum Test Guide for 053 plate for test locations and replacement parts.

# OE Exploded View

## Jaguar ZF6HP26, M-Shift Shown Here

### Lower Valve Body Descriptions

I.D No.	Description
101	Manual Valve
102	Lubrication Control Valve
103	Converter Release Regulator Valve
104	Main Pressure Regulator Valve
105	Bypass Clutch Control Regulator Valve
106	Clutch E Latch Valve
107	Clutch E Control Pressure Regulator Valve
108	Clutch A Control Pressure Regulator Valve
109	Delay Accumulator Piston*
110	Solenoid Multiplex Valve
111	Drive Enable Valve
112	Clutch D1 Latch Valve
113	Solenoid Pressure Regulator Valve
115	Clutch B Latch Valve
116	Clutch A Latch Valve

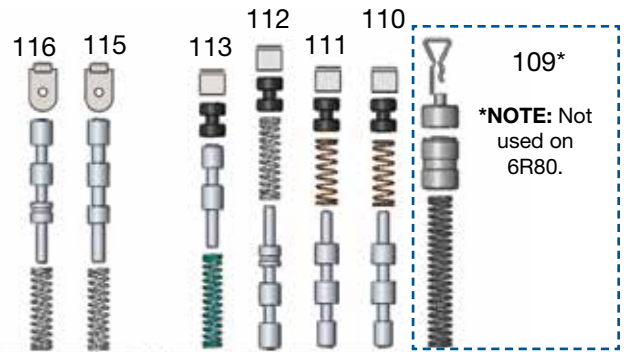

109\*  
\*NOTE: Not used on 6R80.

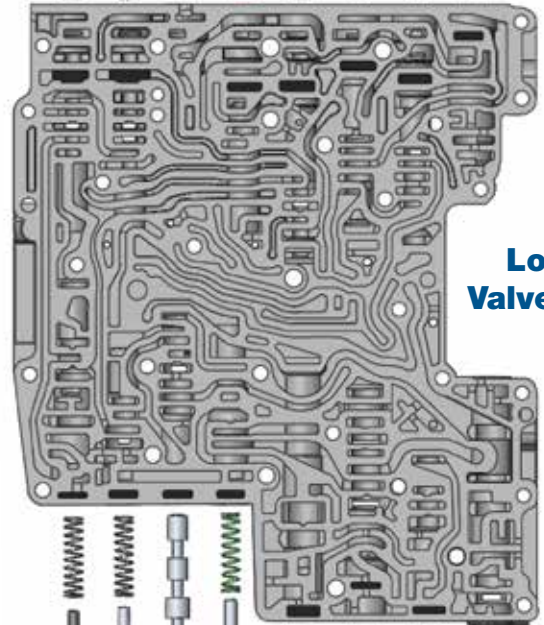

**Lower Valve Body**

### Upper Valve Body Descriptions

I.D. No.	Description
201	Clutch B Regulator Valve
202	Clutch D2 Regulator Valve**
203	Clutch D2 Latch Valve
203A	Position D Valve
204	Clutch C Regulator Valve
205	Clutch D1 Control Pressure Regulator Valve***

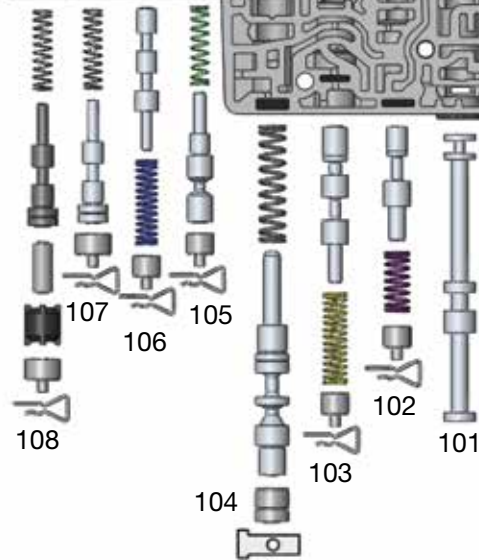

### Upper Valve Body

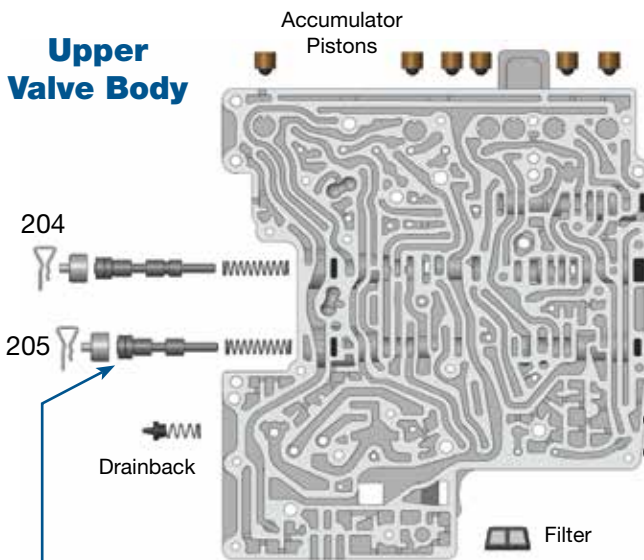

Accumulator Pistons

Drainback

Filter

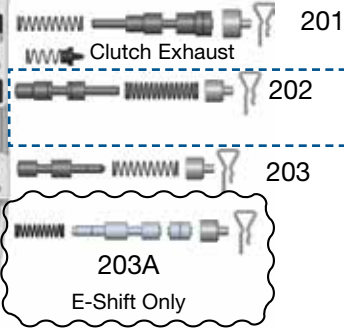

\*\*NOTE: Entire line-up eliminated on 2010-Later 6R80.

203A  
E-Shift Only

13mm No Spring 205

\*\*\*NOTE: The D1 Control Valve is dimensionally different on 2010-Later 6R80. The bore plug also reduced in size.



**Orifice Legend**

Unit Stock or Tag No.

Orifice Location	Valve/Circuit Checked	Sonnax Part Number	*Special Instructions	Actual Vacuum Reading	Min. Vacuum Standard
<b>Lower Valve Body</b>	102A	Lubrication Control Valve, Inboard End	95740-11K		
	102B	Lubrication Control Valve, Outboard End & Bore Plug	95740-11K, -19K		
	103A SI*	Converter Release Regulator Valve	95740-05K	Check w/valve at rest	
	103B SI*	Converter Release Regulator Valve	95740-05K	Invert valve, center inboard spool in passage	
	104A	Main Pressure Regulator Valve, Boost/Spring Side	95740-01K, -03K, -46K, -44K	Use .125" Shim to Force Inboard	
	104B	Main Pressure Regulator Valve			
	104C	Main Pressure Regulator Valve			
	104D	Main Pressure Regulator Valve, Balance/Sleeve			
	105B	Bypass CC Reg. Valve, Apply Side & Bore Plug	95740-19K		
	106A	Clutch E Latch Valve Inboard End			
	107A	Clutch E Control Pressure Regulator Valve	95740-08K		
	107B SI*	Clutch E Control Pressure Regulator Valve	95740-08K	Ensure valve seated outboard if no spring	
	107C	Clutch E Control PR Valve, Apply Side & Bore Plug	95740-08K, -19K		
	108A SI*	Clutch A Control Pressure Regulator Valve	95740-09K, -21K	Ensure valve seated outboard if no spring	
	108B	Clutch A Control PR Valve & Boost Valve	95740-09K, -21K		
	108C	Clutch A Control Boost Valve & Bore Plug	95740-09K, -21K, 19K		
	109A	MV3 Solenoid, E-Shift; MV1 Solenoid Damper, M-Shift		Solenoid damper not used on 6R80	
	110A	Solenoid Multiplex Valve			
	110B	Solenoid Multiplex Valve and Bore Plug	95740-25K		
	110C-E	Shift Valve 2, E-Shift; Solenoid Multiplex Valve, M-Shift			
	111A	Drive Enable Valve			
	111B	Drive Enable Valve Bore Plug	95740-25K		
	112A	D1 Clutch Latch Valve			
	112B	D1 Clutch Latch Valve Bore Plug	95740-25K		
	113A SI*	Solenoid Pressure Regulator	95740-17K	Use .125" Shim to Force Inboard	
	113B SI*	Solenoid Pressure Regulator	95740-17K	Check at Rest	
	113C	Solenoid Pressure Regulator Valve Bore Plug	95740-17K, -25K		
	115A	Clutch B Latch Valve			
116A	Clutch A Control Pressure Regulator Valve	95740-09K			
<b>Upper Valve Body</b>	ACC A SI*	EDS6 TCC Damper, Accumulator Piston	95740-15K	Invert Accumulator Piston	
	ACC B SI*	EDS4 VFS4 Damper, Accumulator Piston	95740-15K		
	ACC C SI*	EDS5 VFS5 Damper, Accumulator Piston	95740-15K		
	ACC D SI*	EDS3 VFS3 Damper, Accumulator Piston	95740-15K		
	ACC E SI*	EDS2 VFS2 Damper, Accumulator Piston	95740-15K		
	ACC F SI*	EDS1 VFS1 Damper, Accumulator Piston	95740-15K		
	201A	Clutch B Regulator Valve			
	201B	Clutch B Regulator Valve, Apply Side & Bore Plug	95740-19K		
	202A SI*	Clutch D2 Regulator Valve		Not Used on 2011-Later 6R80	
	202B SI*	Clutch D2 Regulator Valve Bore Plug	95740-19K		
	203A	Clutch D2 Latch Valve			
	203B-E	Clutch D2 Latch Valve Bore Plug E-Shift	95740-19K		
	203B-M	Clutch D2 Latch Valve Bore Plug M-Shift	95740-19K		
	204A	Clutch C Regulator Valve			
	204B	Clutch C Regulator Valve, Apply Side & Bore Plug	95740-19K		
205A	Clutch D1 Control Pressure Regulator Valve	95740-08K	Not Used on 2011-Later 6R80		
205B	Clutch D1 Control PR Valve, Apply Side & Bore Plug	95740-08K, -19K	Use 13mm plug w/-19K 2011-Up 6R80		
203AA-E	Position Valve E-Shift				

**NOTE:** E-Shift are units with NO manual valve. M-Shift are units with manual valve. "X" orifice locations on plate are for air inlet and do not require testing.