

Oversized Line Pressure Control Valve Kit



Part No.
126740-08K

- Valve
- Spring
- End Plug
- O-Ring (2)

1 Extra

Tool Kit



Part No.
F-126740-TL8

- Reamer
- Reamer Jig
- Guide Pin

NOTE: Sonnax “F-Tool” kits designed to service a specific bore require the VB-FIX, a self-aligning valve body reaming fixture. More information and instructions can be found online at www.sonnax.com.

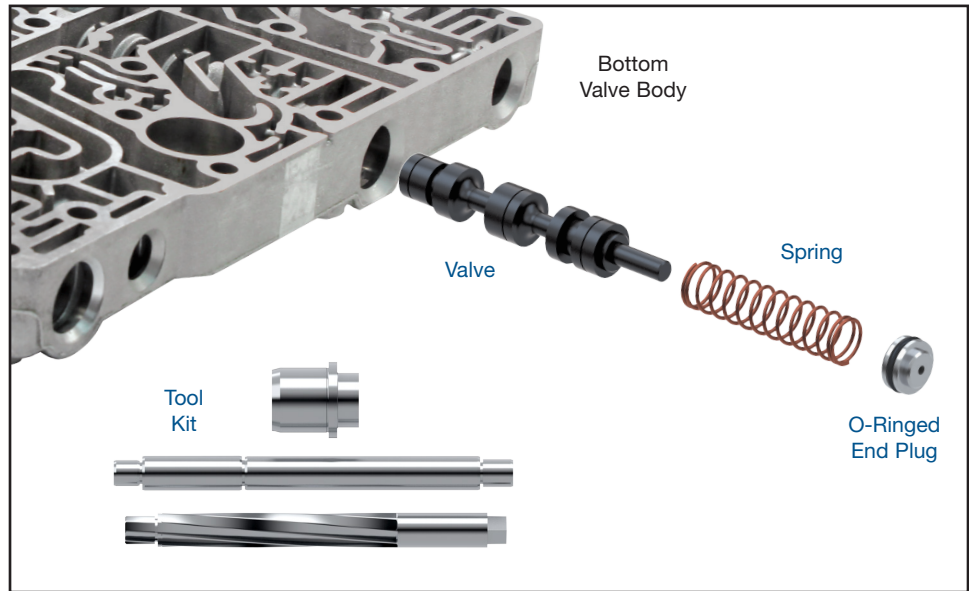

Ford 6R140

1. Disassembly

- Remove OE retainer and set aside for reuse.
- Remove and discard OE end plug, spring and valve.

2. Bore Reaming

Ream line pressure control bore (for reaming instructions/reamer care, please visit www.sonnax.com). Sonnax reaming tool kit F-126740-TL8 and VB-FIX are required for this operation.



NOTE: Due to the large cutting diameter of the reamer, recommend using drill for reaming rather than a speed handle. Drill must not exceed 200 RPM.

3. Installation & Assembly

- Ensure all debris is removed from valve bore and body.
- Install Sonnax valve with spring stem facing outward.
- Install Sonnax spring, ensuring it seats over valve stem.
- Place O-ring on Sonnax end plug.
- Lubricate O-ring with Sonnax Slippery Stick™ O-LUBE. Roll O-ringed plug on clean bench to size O-ring into groove.

- Install end plug with threaded hole facing outward. Secure with OE retainer.

4. Final Testing

Vacuum testing at the port(s) indicated holds the recommended minimum 16 in.-Hg.



NOTE: For accurate vacuum testing results, drop a 1/8" dia. checkball in front of valve (bottom of bore) before testing. **Ensure checkball is removed after testing!**

