

**Oversized Bypass
Clutch Control
Valve Kit**



Part No.
95740-73K

- Valve
- End Plug
- O-Rings (2) 1 Extra

NOTE: Kit is not compatible with ZF6HP19/26/32 (Gen. 1) units. To differentiate between Gen. 1 and Gen. 2 valve bodies, refer to ZF Identification Guide at www.sonnax.com.

Tool Kit



Part No.
F-95740-TL73

- Reamer
- Reamer Jig
- Guide Pin

NOTE: Sonnax "F-Tool" kits designed to service a specific bore require the VB-FIX, a self-aligning valve body reaming fixture. More information and instructions can be found online at www.sonnax.com.

ZF6HP21, ZF6HP28, ZF6HP34

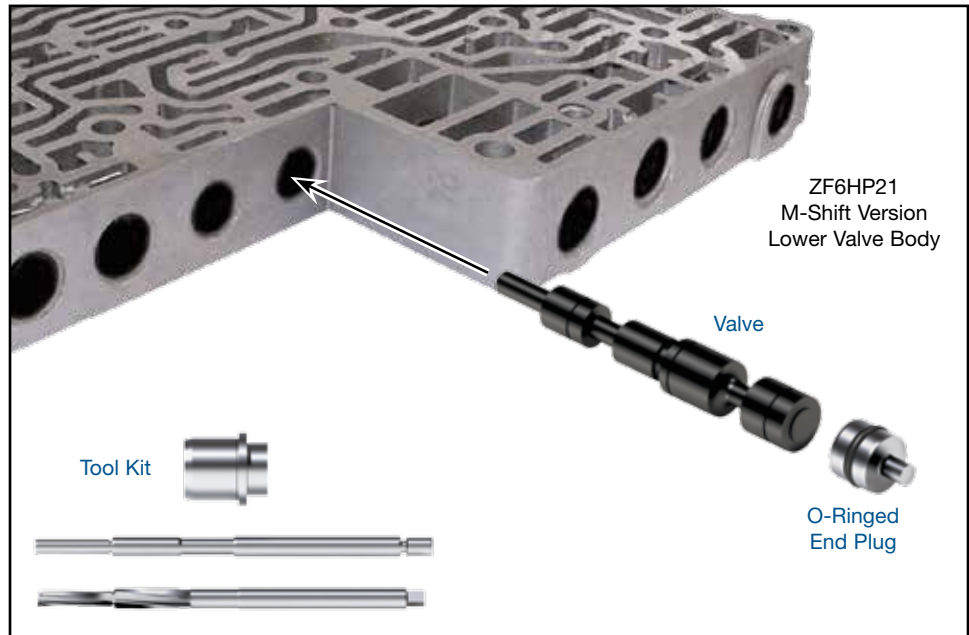

1. Disassembly

- Remove OE retaining clip and save for reuse.
- Remove and discard the OE end plug and bypass clutch control valve.
- Remove the OE spring and save for reuse.

2. Bore Reaming

Ream bypass clutch control bore (for reaming instructions/reamer care, please visit www.sonnax.com). Sonnax reaming tool kit **F-95740-TL73** and **VB-FIX** are required for this operation.

3. Installation & Assembly

- Be certain all debris has been removed from the valve bore and valve body.
- Reinstall the OE spring.
- Install the Sonnax oversized bypass clutch control valve, spring guide first (as shown), ensuring the spring inner diameter fits over the guide.
- Install one Sonnax O-Ring into the groove on the Sonnax end plug. Lubricate the mounted O-ring, end plug and bore with a small amount of TransJel™, Sonnax Slippery Stick **O-LUBE**, or new ATF/STP. Roll the O-ringed end plug on the bench to size and install the end plug into the bore.
- Reinstall the OE retaining clip.

4. Final Testing

Vacuum testing at the port(s) indicated holds the recommended minimum 18 in-Hg.

